



# EMC TEST REPORT

For

## Static Var Generator

**Model No.: SVG-400-35K-4L, 5 Kvar, 10Kvar, 15Kvar, 20Kvar, 35Kvar, 50Kvar, 70Kvar, 100Kvar**

Prepared for : Cook Cooper Electric (shanghai) Co., Ltd.

Address : Room A56, 4th Floor, Block B 505 Xinbei Road Minhang District Shanghai

Prepared By : Guangdong KAIXU Testing Technology Co., Ltd.

Address : Room 215, Building 2, No. 123, Dongcheng Section, Guanlong Road, Dongcheng Street, Dongguan City, Guangdong Province, China

Tel : +86-755-85254458

Fax : +86-755-85254458

Web : [www.kti-lab.com](http://www.kti-lab.com)

Report Number : KTi251107E309

Date of Receipt : Nov. 07, 2025

Date of Test : Nov. 07-18, 2025

Date of Report : Nov. 19, 2025

## Table of Contents

1 General description .....	5
1.1 Feature of equipment under test (EUT) .....	5
1.2 Test mode .....	5
1.3 Test mode .....	5
1.4 Test conditions .....	5
1.5 Ancillary equipment list .....	5
1.6 Measurement Uncertainty .....	6
2 Testing site .....	6
3 List of test equipment .....	7
4 EMC emission test .....	10
4.1 Conducted emission .....	10
4.2 Radiated emission .....	13
4.3 Harmonic current emission / Voltage fluctuations & flicker .....	19
5 Immunity test .....	20
5.1 Electrostatic discharge immunity (ESD) .....	20
5.2 RF electromagnetic field immunity (RS) .....	24
5.3 Fast transients immunity (EFT) .....	26
5.4 Surges immunity .....	27
5.5 Injected current immunity (CS) .....	29
5.6 Voltage interruptions voltage Dips .....	30
Photographs of the Test Setup .....	32
Photographs of the Test EUT .....	33

**Test Result Certification**

Applicant's name: Cook Cooper Electric (shanghai) Co., Ltd.

Address: Room A56, 4th Floor, Block B 505 Xinbei Road Minhang District Shanghai

Manufacture's name: Cook Cooper Electric (shanghai) Co., Ltd.

Address: Room A56, 4th Floor, Block B 505 Xinbei Road Minhang District Shanghai

Product name: Static Var Generator

Trademark: Cooke kolb

Model name: SVG-400-35K-4L, 5 Kvar, 10Kvar, 15Kvar, 20Kvar, 35Kvar, 50Kvar, 70Kvar, 100Kvar

Standards: ETSI EN 301 489-1 V2.2.3 (2019-11)  
ETSI EN 301 489-17V3.2.4 (2020-09)

*This device described above has been tested by Guangdong KAIXU Testing Technology Co., Ltd. and the test results show that the equipment under test (EUT) is in compliance with the Radio equipment directive requirements. And it is applicable only to the tested sample identified in the report.*

Tested by:	<u>Kevin Yang</u>
	Kevin Yang                      Nov. 19, 2025
Reviewed by:	<u>Terry Huang</u>
	Terry Huang                      Nov. 19, 2025
Approved by:	<u>Store Chu</u>
	Store Chu                      Nov. 19, 2025

## Summary of Test Result

Item	Description of Test	Result
EMC emission		
1	Conducted emission	Pass
2	Radiated emission	Pass
3	Harmonic current emission	Pass
4	Voltage fluctuations & flicker	Pass
Immunity		
1	Electrostatic discharge immunity (ESD)	Pass
2	Radiated electromagnetic field immunity(RS)	Pass
3	Fast transients / burst immunity (EFT)	Pass
4	Surge immunity	Pass
5	Conducted disturbance immunity (CS)	Pass
6	Voltage interruptions & voltage Dips immunity	Pass

N/A\*Not Applicable.

# 1 General description

## 1.1 Feature of equipment under test (EUT)

Product name:	Static Var Generator
Model name:	SVG-400-35K-4L
Series Model:	5 Kvar, 10Kvar, 15Kvar, 20Kvar, 35Kvar, 50Kvar, 70Kvar, 100Kvar
Different of series model:	All models are identical for each other except the model number.
Power source:	AC220-400V, 50/60Hz, 50A Max
Adapter information:	N/A
Antenna designation:	PCB antenna
Antenna Gain:	0dBi

## 1.2 Test mode

## 1.3 Test mode

To investigate the maximum EMI emission characteristics generates from EUT, the test system was pre-scanning tested base on the consideration of following EUT operation mode or test configuration mode which possible have effect on EMI emission level. Each of these EUT operation mode(s) or test configuration mode(s) mentioned above was evaluated respectively.

For Radiated Test	
Final Test Mode	Description
Mode 1	Link mode
Mode 2	Working

NOTE: The test modes were carried out for all operation modes. The final test mode of the EUT was the worst test mode for EMI, and its test data was showed.

## 1.4 Test conditions

During the measurement the environmental conditions were within the listed ranges:

- Temperature: 0°C~40°C
- Humidity: 30%~70% (30%~60% for ESD test)
- Atmospheric pressure: 98kPa~101kPa

## 1.5 Ancillary equipment list

Equipment	Model	S/N	Manufacturer
Adapter	/	/	/

**1.6 Measurement Uncertainty**Measurement Uncertainty for a Level of Confidence of 95 %,  $U=2xUc(y)$ 

Conducted emission(150kHz~30MHz)	± 2.5 dB
Radiated emission(30MHz~1GHz)	± 4.2 dB
Radiated emission (above 1GHz)	± 4.3 dB
Temperature	±1 degree
Humidity	± 5 %

**2 Testing site**

Test laboratory:	Guangdong KAI XU Testing Technology Co., Ltd.
Laboratory location:	Room 215, Building 2, No. 123, Dongcheng Section, Guanlong Road, Dongcheng Street, Dongguan City, Guangdong Province, China
Telephone:	(86-755)85254458
Fax:	(86-755)85254458

### 3 List of test equipment

For conducted emission at the mains terminals test

Name of Equipment	Manufacturer	Model	Equipment No.	Serial No.	Last Cal.	Cal. Interval
EMI Test Receiver	Rohde&Schwarz	ESCI	KTi-EL-203	1166.5950.03-101142	Mar. 03, 2025	1 Year
Pulse Limiter	Rohde&Schwarz	ESH3-Z2	KTi-EL-201	0357.8810.54-101857-hz	Mar. 03, 2025	1 Year
LISN	Rohde&Schwarz	ENV216	KTi-EL-202	3560.6550.12-103020-YU	Mar. 03, 2025	1 Year
Test software	Tonscend	JS32-CE Version 5.0.0				

For radiated emission test (30MHz-1GHz)

Name of Equipment	Manufacturer	Model	Equipment No.	Serial No.	Last Cal.	Cal. Interval
EMI Test Receiver	Rohde&Schwarz	ESCI7	KTi-EL-205	1166.5950.03-100633	Mar. 03, 2025	1 Year
Logarithmic periodic antenna	Schwarzbeck	VULB9168	KTi-EL-209	01145	Mar. 06, 2025	3 Year
Preamplifier	HP	8447F	KTi-EL-210	1-18-53G22	Mar. 03, 2025	1 Year
3m Anechoic Chamber	Taihe MaoRui	9*6*6	KTi-EL-234	/	Oct. 09, 2024	5 Year
Test software	Tonscend	JS32-RE Version 5.0.0				

For radiated emission test (1GHz above)

Name of Equipment	Manufacturer	Model	Equipment No.	Serial No.	Last Cal.	Cal. Interval
EMI Test Receiver	Rohde&Schwarz	ESCI 7	KTi-EL-205	1166.5950.03-100633	Mar. 03, 2025	1 Year
Horn antenna	Schwarzbeck	BBHA9120D	KTi-EL-239	03083	Mar. 06, 2025	3 Year
Preamplifier	/	1-18-53G22	KTi-EL-240	2501020026	Mar. 03, 2025	1 Year
Test software	Tonscend	JS32-RE Version 5.0.0				

For harmonic current emissions and voltage fluctuations/flicker test

Name of Equipment	Manufacturer	Model	Equipment No.	Serial No.	Last Cal.	Cal. Interval
AC Power Source	California instruments	5001i-400	KTi-EL-248	55979	May 17, 2025	1 Year
Harmonic and Flicker Analyzer	California instruments	PACS-1	KTi-EL-249	72145	May 17, 2025	1 Year
Test software	California Instruments	CTS 4 Version 4.32.0				

## For electrostatic discharge immunity test

Name of Equipment	Manufacturer	Model	Equipment No.	Serial No.	Last Cal.	Cal. Interval
ESD Tester	PRIMA	ESD61002TB	KTi-EL-215	PR9240625796	Mar. 05, 2025	1 Year

## For radio frequency electromagnetic field immunity (R/S) test (DQT)

Name of Equipment	Manufacturer	Model	Equipment No.	Serial No.	Last Cal.	Cal. Interval
Amplifier	Micotop	MPA-80-1000-250	KTi-EL-258	MAP2503096	May 17, 2025	1 Year
Amplifier	Micotop	MPA-1000-6000-100	KTi-EL-259	MPA2503098	May 19, 2025	1 Year
Power Meter	Agilent	E4417A	KTi-EL-260	GB41293356	May 17, 2025	1 Year
Power Sensor	Agilent	E9304A	KTi-EL-261	MY55200008	May 17, 2025	1 Year
Power Sensor	Agilent	E9304A	KTi-EL-262	MY55200004	May 17, 2025	1 Year
Signal Generator	ROHDE&SCHWARZ	SMB100A	KTi-EL-263	102913	May 17, 2025	1 Year
Log-Per-Broadband Antenna	SKET	STLP 9129 PLUS	KTi-EL-264	/	May 19, 2025	3 Year
Audio Analyzer	ROHDE&SCHWARZ	UPP200	KTi-EL-267	120175	May 17, 2025	1 Year

## For electrical fast transient/burst immunity test

Name of Equipment	Manufacturer	Model	Equipment No.	Serial No.	Last Cal.	Cal. Interval
Fast Transient Burst Simulator	PRIMA	EFT61004TA	KTi-EL-218	PR9240743972	Mar. 03, 2025	1 Year
Clamp	PRIMA	PEFT-C105	KTi-EL-219	PEFT-1170	Mar. 03, 2025	1 Year

## For surge immunity test

Name of Equipment	Manufacturer	Model	Equipment No.	Serial No.	Last Cal.	Cal. Interval
Lighting Surge Generator	PRIMA	SUG61005TB-2216	KTi-EL-217	PR200854619	Mar. 03, 2025	1 Year
Coupling/Decoupling Network	PRIMA	SUG-CDN-108	KTi-EL-216	PR924105429	Mar. 03, 2025	1 Year

## For injected currents susceptibility test

Name of Equipment	Manufacturer	Model	Equipment No.	Serial No.	Last Cal.	Cal. Interval
CS Test system	TESEQ	NSG4070	KTi-EL-255	30608	May 17, 2025	1 Year
6dB Attenuator	TESEQ	ATN6075	KTi-EL-256	30783	May 17, 2025	1 Year
CDN	TESEQ	CDN M016	KTi-EL-254	33518	May 17, 2025	1 Year
EM-Clamp	TESEQ	KEMZ 801A	KTi-EL-257	33425	May 17, 2025	1 Year

## For power frequency magnetic field immunity test

Equipment	Manufacturer	Model	Equipment No.	Serial No.	Last Cal.	Cal.Interval
POWER FREQUENCY MAGNETIC FIELD GENERATION	EVERFINE	EMS61000-8K	KTi-EL-273	608002	May 16, 2025	1 Year

## For voltage dips and short interruptions immunity test

Name of Equipment	Manufacturer	Model	Equipment No.	Serial No.	Last Cal.	Cal. Interval
Cycle Sag Simulator	PRIMA	DRP61011TB	KTi-EL-220	PR924086817	Mar. 03, 2025	1 Year

## 4 EMC emission test

### 4.1 Conducted emission

#### 4.1.1 Limits

Frequency (MHz)	Class A (dB $\mu$ V)		Class B (dB $\mu$ V)	
	Quasi-peak	Average	Quasi-peak	Average
0.15 -0.5	79	66	66 - 56 *	56 - 46 *
0.5 -5	73	60	56	46
5 -30	73	60	60	50

#### 4.1.2 Test Procedures

The EUT was placed 0.8 meters from the horizontal ground plane with EUT being connected to the power mains through an Artificial mains networks (AMN). All other support equipment powered from additional AMN. The LISN provide 50 Ohm/ 50uH of coupling impedance for the measuring instrument.

Interconnecting cables that hang closer than 40 cm to the ground plane shall be folded back and forth in the center forming a bundle 30 to 40 cm long.

I/O cables that are not connected to a peripheral shall be bundled in the center. The end of the cable may be terminated, if required, using the correct terminating impedance. The overall length shall not exceed 1 m.

AMN is at least 80 cm from nearest part of EUT chassis.

Setup of the receiver

Frequency	Detector	Setting
0.15MHz – 30MHz	QP	IF bandwidth: 9kHz

#### 4.1.3 Test setup

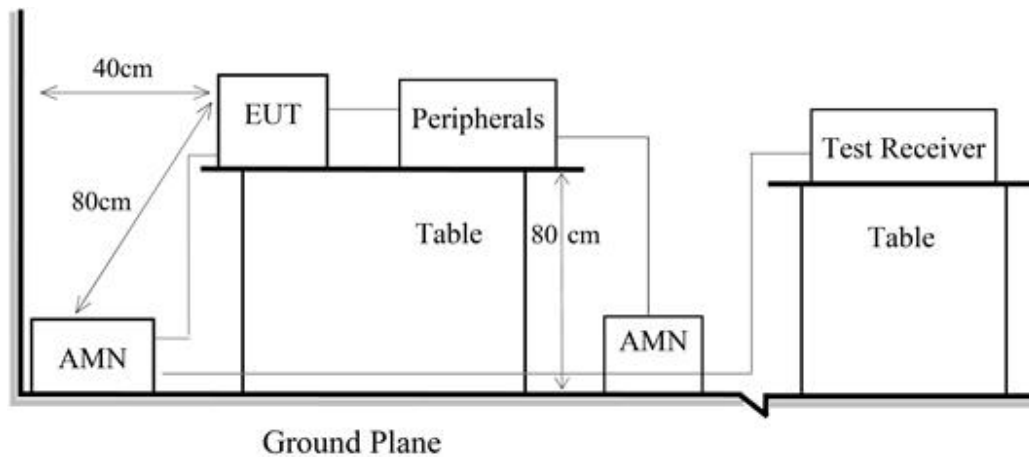

#### 4.1.4 Test Result

PASS

EUT:	Static Var Generator	Model Number:	SVG-400-35K-4L
Test voltage:	AC 230V/50Hz	Test mode:	Mode 1
Pressure:	101kPa	Polarization:	L1
Temperature:	24°C	Relative Humidity:	53%

Line:

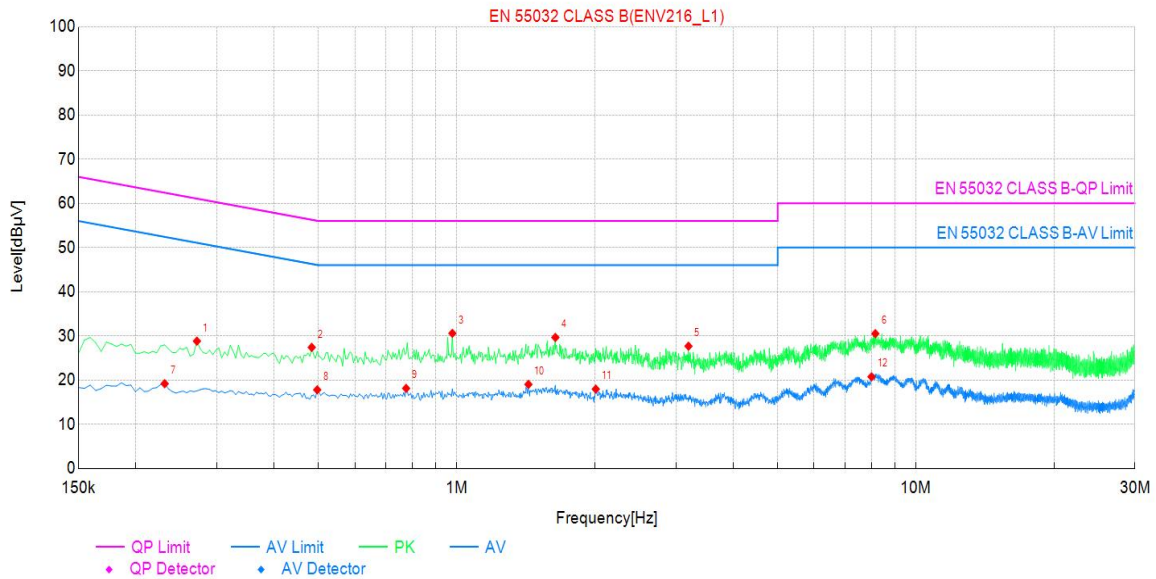

### Suspected Data List

NO.	Frequency [MHz]	Reading [dBµV]	Level [dBµV]	Factor [dB]	Limit [dBµV]	Margin [dB]	Phase	Detector	Verdict
1	0.271500	8.81	28.81	20.00	61.07	32.26	L1	PK	PASS
2	0.483000	7.40	27.40	20.00	56.29	28.89	L1	PK	PASS
3	0.978000	10.58	30.58	20.00	56.00	25.42	L1	PK	PASS
4	1.639500	9.65	29.65	20.00	56.00	26.35	L1	PK	PASS
5	3.196500	7.67	27.67	20.00	56.00	28.33	L1	PK	PASS
6	8.160000	10.50	30.50	20.00	60.00	29.50	L1	PK	PASS
7	0.231000	-0.82	19.18	20.00	52.41	33.23	L1	AV	PASS
8	0.496500	-2.22	17.78	20.00	46.06	28.28	L1	AV	PASS
9	0.775500	-1.88	18.12	20.00	46.00	27.88	L1	AV	PASS
10	1.432500	-0.99	19.01	20.00	46.00	26.99	L1	AV	PASS
11	2.008500	-2.05	17.95	20.00	46.00	28.05	L1	AV	PASS
12	8.007000	0.74	20.74	20.00	50.00	29.26	L1	AV	PASS

Note: (1) Level = Reading + Factor

(2) Margin = Limit - Level

EUT:	Static Var Generator	Model Number:	SVG-400-35K-4L
Test voltage:	AC 230V/50Hz	Test mode:	Mode 1
Pressure:	101kPa	Polarization:	N
Temperature:	24°C	Relative Humidity:	53%

Neutral:

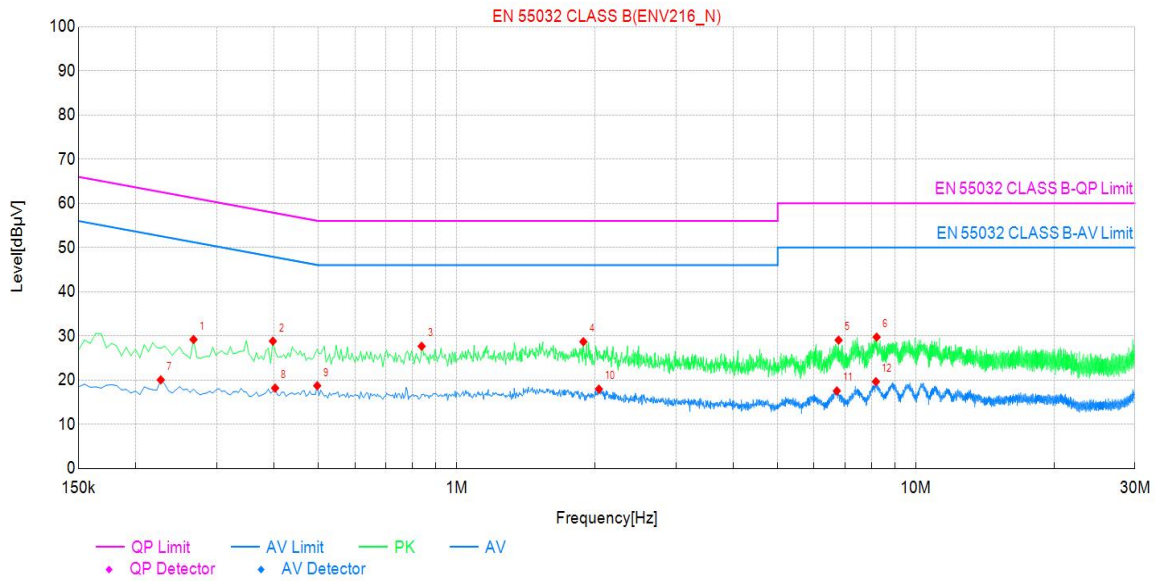

### Suspected Data List

NO.	Frequency [MHz]	Reading [dBµV]	Level [dBµV]	Factor [dB]	Limit [dBµV]	Margin [dB]	Phase	Detector	Verdict
1	0.267000	9.18	29.18	20.00	61.21	32.03	N	PK	PASS
2	0.397500	8.81	28.81	20.00	57.91	29.10	N	PK	PASS
3	0.838500	7.65	27.65	20.00	56.00	28.35	N	PK	PASS
4	1.887000	8.68	28.68	20.00	56.00	27.32	N	PK	PASS
5	6.787500	9.03	29.03	20.00	60.00	30.97	N	PK	PASS
6	8.214000	9.72	29.72	20.00	60.00	30.28	N	PK	PASS
7	0.226500	0.03	20.03	20.00	52.58	32.55	N	AV	PASS
8	0.402000	-1.82	18.18	20.00	47.81	29.63	N	AV	PASS
9	0.496500	-1.29	18.71	20.00	46.06	27.35	N	AV	PASS
10	2.040000	-2.04	17.96	20.00	46.00	28.04	N	AV	PASS
11	6.729000	-2.46	17.54	20.00	50.00	32.46	N	AV	PASS
12	8.182500	-0.37	19.63	20.00	50.00	30.37	N	AV	PASS

Note: (1) Level = Reading + Factor

(2) Margin = Limit - Level

4.2.1 Limits

Frequency (MHz)	Class B Limit (dBµV/m)		Class A Limit (dBµV/m)	
	Quasi-peak/Peak	Average	Quasi-peak/Peak	Average
30 ~ 230	40 (at 3m)	/	50 (at 3m)	/
230 ~ 1000	47 (at 3m)	/	57 (at 3m)	/
1000 ~ 3000	70 (at 3m)	50 (at 3m)	76 (at 3m)	56 (at 3m)
3000 ~ 6000	74 (at 3m)	54 (at 3m)	80 (at 3m)	60 (at 3m)

4.2.2 Test Procedures

- a. The measuring distance of at 3 m shall be used for measurements at frequency up to 1GHz. For frequencies above 1GHz, any suitable measuring distance may be used.
- b. The EUT was placed on the top of a rotating table 0.8 meters above the ground at a 10 meter open area test site. The table was rotated 360 degrees to determine the position of the highest radiation.
- c. The height of the equipment or of the substitution antenna shall be 0.8 m; the height of the test antenna shall vary between 1 m to 4 m. Both horizontal and vertical polarizations of the antenna are set to make the measurement.
- d. The initial step in collecting conducted emission data is a spectrum analyzer peak detector mode pre-scanning the measurement frequency range. Significant peaks are then marked and then Quasi Peak detector mode re-measured.
- e. If the Peak Mode measured value compliance with and lower than Quasi Peak Mode Limit, the EUT shall be deemed to meet QP Limits and then no additional QP Mode measurement performed.
- f. For the actual test configuration, please refer to the related item –EUT Test Photos.

Setup of receiver

Frequency	Detector	Setting
30MHz – 1GHz	QP	IF bandwidth: 120kHz
Above 1GHz	Peak	RBW: 1MHz, VBW: 3MHz
	AV	RBW: 1MHz, VBW: 10Hz

## 4.2.3 Test Setup

### Radiated Emission Test Set-Up Frequency Below 1 GHz

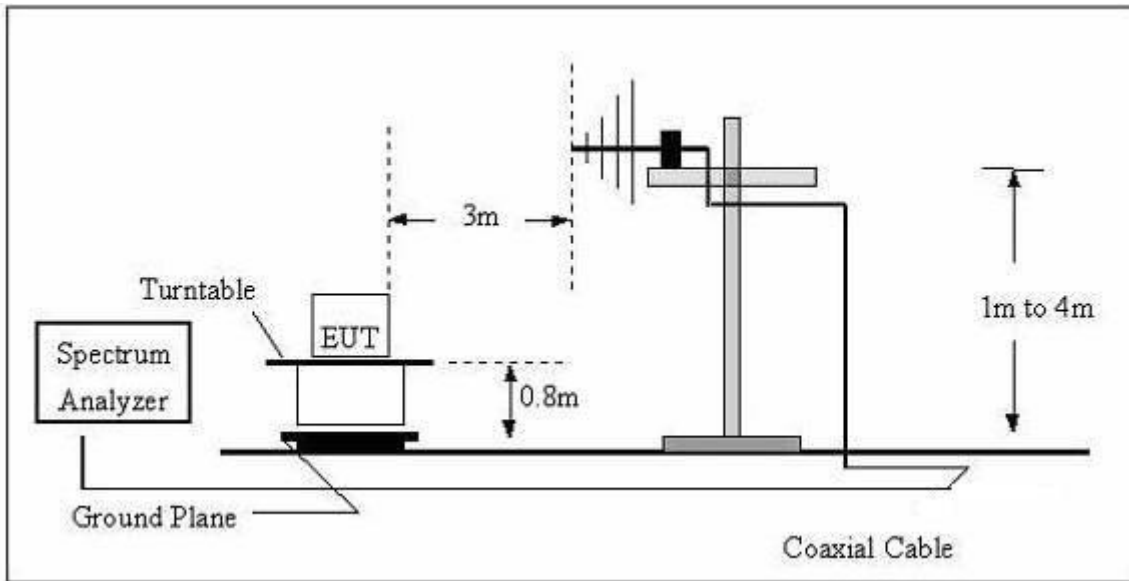

### Radiated Emission Test Set-Up Frequency Above 1GHz

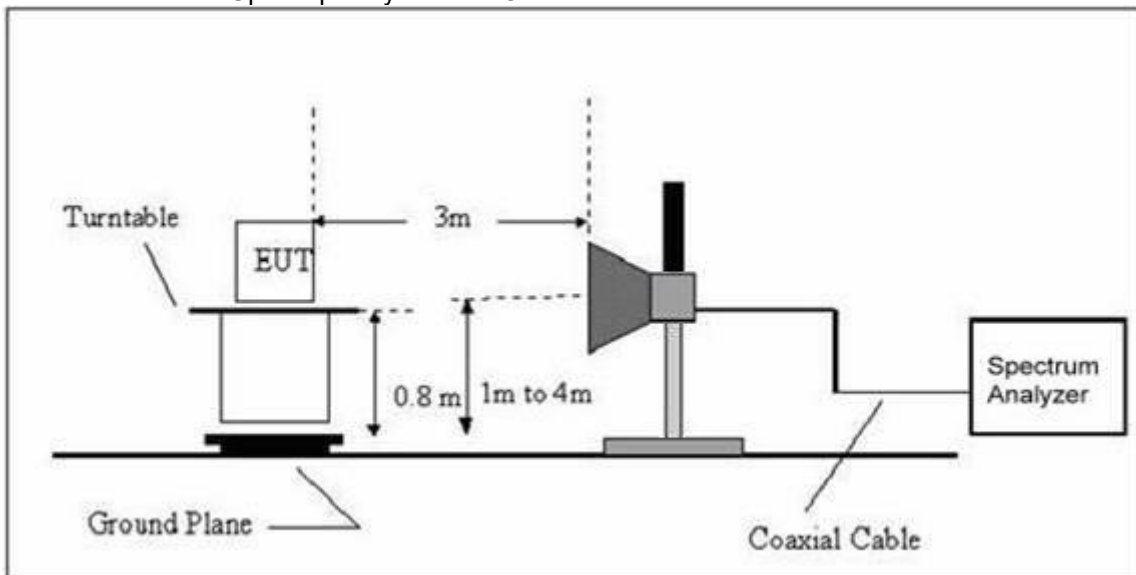

### 4.2.4 Test Result

Below 1 GHz

EUT:	Static Var Generator	Model Number:	SVG-400-35K-4L
Test voltage:	AC 230V/50Hz	Test mode:	Mode 1
Pressure:	101kPa	Polarization:	Horizontal
Temperature:	25°C	Relative Humidity:	56%

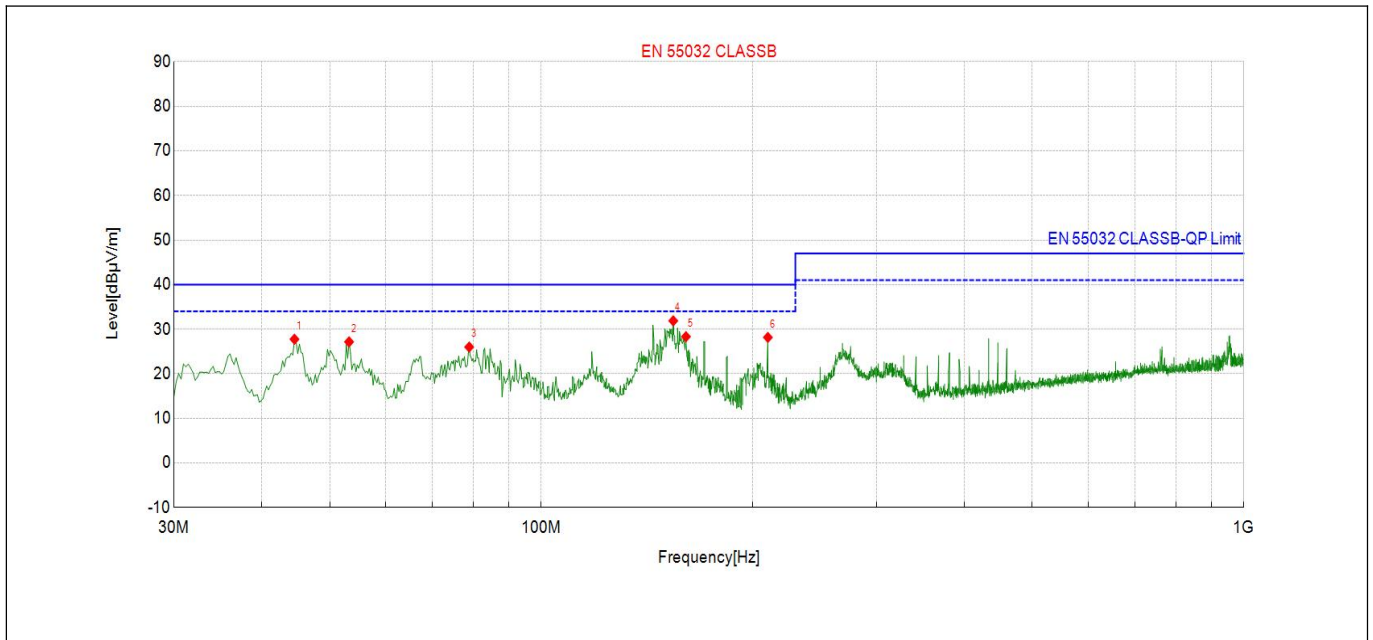

Suspected Data List											
NO.	Frequency [MHz]	Reading [dBµV]	Level [dBµV/m]	Factor [dB/m]	Limit [dBµV/m]	Margin [dB]	Height [cm]	Angle [°]	Det	Pol	Verdict
1	44.55	44.86	27.76	-17.10	40.00	12.24	100	335	PK	Hori	PASS
2	53.28	44.66	27.17	-17.49	40.00	12.83	100	43	PK	Hori	PASS
3	78.99	46.57	26.01	-20.56	40.00	13.99	100	353	PK	Hori	PASS
4	154.16	47.99	31.88	-16.11	40.00	8.12	100	166	PK	Hori	PASS
5	160.71	44.44	28.33	-16.11	40.00	11.67	100	53	PK	Hori	PASS
6	210.18	47.73	28.16	-19.57	40.00	11.84	100	1	PK	Hori	PASS

Note: (1) Level = Reading + Factor

(2) Margin = Limit - Level

Note 1: The test modes were carried out for all operation modes. The worst test mode for test data was showed in the report.

2: Exceeding the emission limit is the main frequency.

3: Peak test margin is greater than 20dBm, so AVG is also pass.

EUT:	Static Var Generator	Model Number:	SVG-400-35K-4L
Test voltage:	AC 230V/50Hz	Test mode:	Mode 1
Pressure:	101kPa	Polarization:	Vertical
Temperature:	25°C	Relative Humidity:	57%

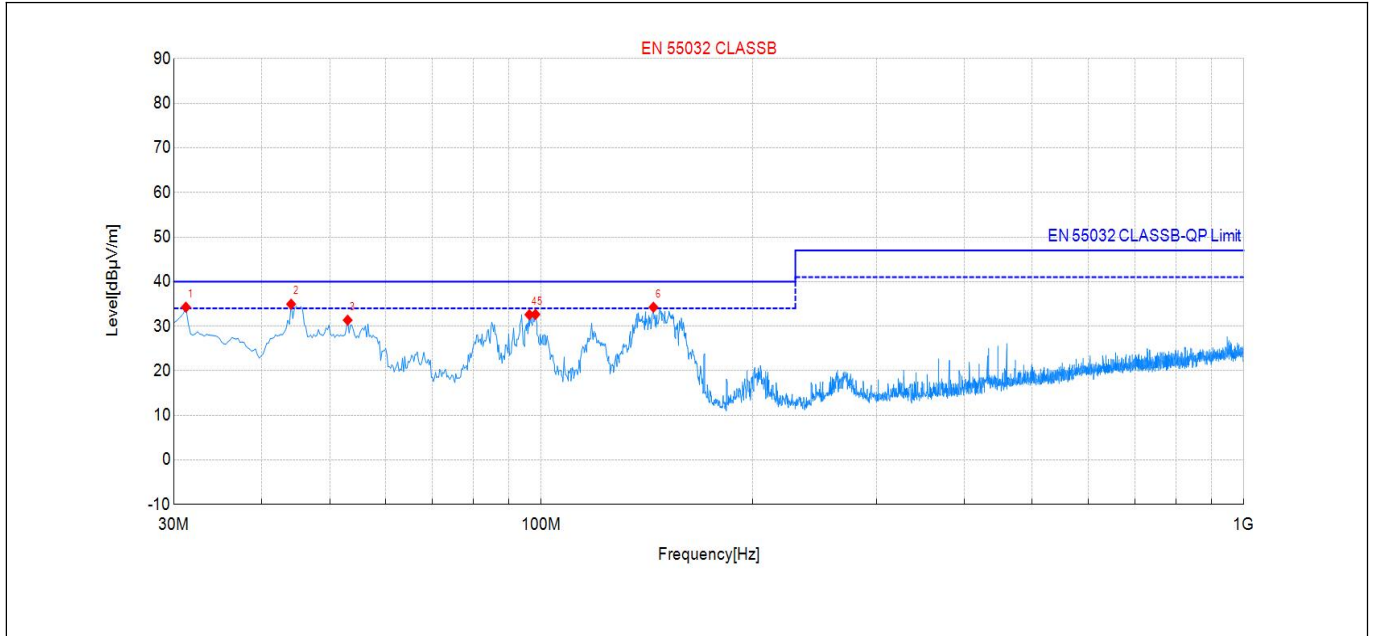

Suspected Data List											
NO.	Frequency [MHz]	Reading [dBµV]	Level [dBµV/m]	Factor [dB/m]	Limit [dBµV/m]	Margin [dB]	Height [cm]	Angle [°]	Det	Pol	Verdict
1	31.21	51.99	34.27	-17.72	40.00	5.73	100	166	PK	Vert	PASS
2	44.07	52.05	34.96	-17.09	40.00	5.04	100	324	PK	Vert	PASS
3	53.04	48.82	31.36	-17.46	40.00	8.64	100	316	PK	Vert	PASS
4	96.20	52.75	32.60	-20.15	40.00	7.40	100	12	PK	Vert	PASS
5	98.14	52.68	32.66	-20.02	40.00	7.34	100	52	PK	Vert	PASS
6	144.46	50.53	34.26	-16.27	40.00	5.74	100	12	PK	Vert	PASS

Note:(1)Level=Reading+Factor  
 (2)Margin=Limit-Level

Note 1: The test modes were carried out for all operation modes. The worst test mode for test data was showed in the report.

- 2: Exceeding the emission limit is the main frequency.
- 3: Peak test margin is greater than 20dBm, so AVG is also pass.

EUT:	Static Var Generator	Model Number:	SVG-400-35K-4L
Test voltage:	AC 230V/50Hz	Test mode:	Mode 1
Pressure:	101kPa	Polarization:	Horizontal
Temperature:	25°C	Relative Humidity:	56%

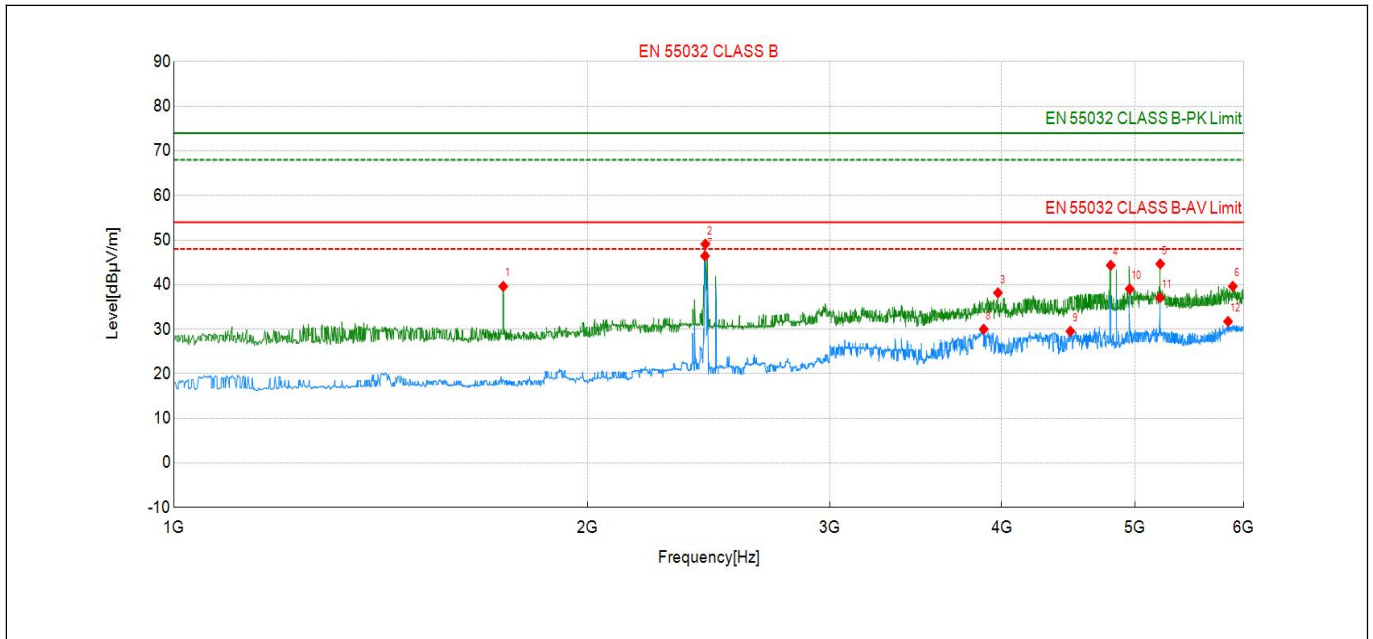

**Suspected Data List**

NO.	Frequency [MHz]	Reading [dBµV]	Level [dBµV/m]	Factor [dB/m]	Limit [dBµV/m]	Margin [dB]	Height [cm]	Angle [°]	Det	Pol	Verdict
1	1736.25	68.47	39.61	-28.86	74.00	34.39	100	310	PK	Hori	PASS
2	2435.00	76.54	49.10	-27.44	74.00	24.90	100	217	PK	Hori	PASS
3	3975.00	62.49	38.15	-24.34	74.00	35.85	100	32	PK	Hori	PASS
4	4801.25	66.96	44.34	-22.62	74.00	29.66	100	359	PK	Hori	PASS
5	5216.25	66.60	44.64	-21.96	74.00	29.36	100	135	PK	Hori	PASS
6	5890.00	60.86	39.64	-21.22	74.00	34.36	100	279	PK	Hori	PASS
7	2433.75	73.88	46.44	-27.44	54.00	7.56	100	300	AV	Hori	PASS
8	3881.25	54.47	29.99	-24.48	54.00	24.01	100	359	AV	Hori	PASS
9	4487.50	52.81	29.53	-23.28	54.00	24.47	100	145	AV	Hori	PASS
10	4956.25	61.34	39.05	-22.29	54.00	14.95	100	63	AV	Hori	PASS
11	5215.00	59.04	37.08	-21.96	54.00	16.92	100	135	AV	Hori	PASS
12	5843.75	53.01	31.74	-21.27	54.00	22.26	100	359	AV	Hori	PASS

Note:(1)Level=Reading+Factor

(2)Margin=Limit-Level

Note 1: The test modes were carried out for all operation modes. The worst test mode for test data was showed in the report.

2: Exceeding the emission limit is the main frequency.

3: Peak test margin is greater than 20dBm, so AVG is also pass.

EUT:	Static Var Generator	Model Number:	SVG-400-35K-4L
Test voltage:	AC 230V/50Hz	Test mode:	Mode 1
Pressure:	101kPa	Polarization:	Vertical
Temperature:	25°C	Relative Humidity:	57%

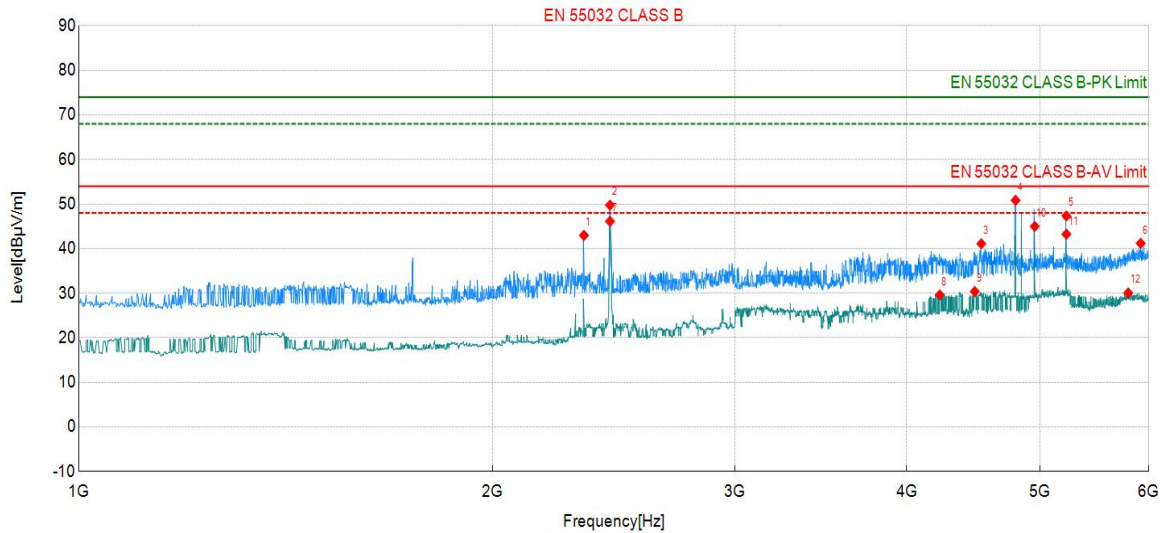

### Suspected Data List

NO.	Frequency [MHz]	Reading [dBµV]	Level [dBµV/m]	Factor [dB/m]	Limit [dBµV/m]	Margin [dB]	Height [cm]	Angle [°]	Det	Pol	Verdict
1	2330.00	70.72	42.98	-27.74	74.00	31.02	100	1	PK	Vert	PASS
2	2433.75	77.20	49.76	-27.44	74.00	24.24	100	1	PK	Vert	PASS
3	4532.50	64.29	41.11	-23.18	74.00	32.89	100	297	PK	Vert	PASS
4	4800.00	73.46	50.84	-22.62	74.00	23.16	100	184	PK	Vert	PASS
5	5226.25	69.29	47.34	-21.95	74.00	26.66	100	308	PK	Vert	PASS
6	5918.75	62.38	41.19	-21.19	74.00	32.81	100	297	PK	Vert	PASS
7	2433.75	73.57	46.13	-27.44	54.00	7.87	100	1	AV	Vert	PASS
8	4227.50	53.45	29.63	-23.82	54.00	24.37	100	1	AV	Vert	PASS
9	4482.50	53.67	30.38	-23.29	54.00	23.62	100	358	AV	Vert	PASS
10	4956.25	67.29	45.00	-22.29	54.00	9.00	100	163	AV	Vert	PASS
11	5226.25	65.19	43.24	-21.95	54.00	10.76	100	308	AV	Vert	PASS
12	5796.25	51.38	30.06	-21.32	54.00	23.94	100	358	AV	Vert	PASS

Note:(1)Level=Reading+Factor

(2)Margin=Limit-Level

Note 1: The test modes were carried out for all operation modes. The worst test mode for test data was showed in the report.

2: Exceeding the emission limit is the main frequency.

3: Peak test margin is greater than 20dBm, so AVG is also pass.

### 4.3 Harmonic current emission / Voltage fluctuations & flicker

#### 4.3.1 Test Procedures

The EUT was installed and placed on a non-conductive table and operated to produce the maximum harmonic components under normal operating conditions for each successive harmonic component in turn.

The correspondent test program of test instrument to measure the current harmonics / voltage fluctuations & flicker emanated from EUT. The measure time shall be not less than the time necessary for the EUT to be exercised.

#### 4.3.2 Test Setup

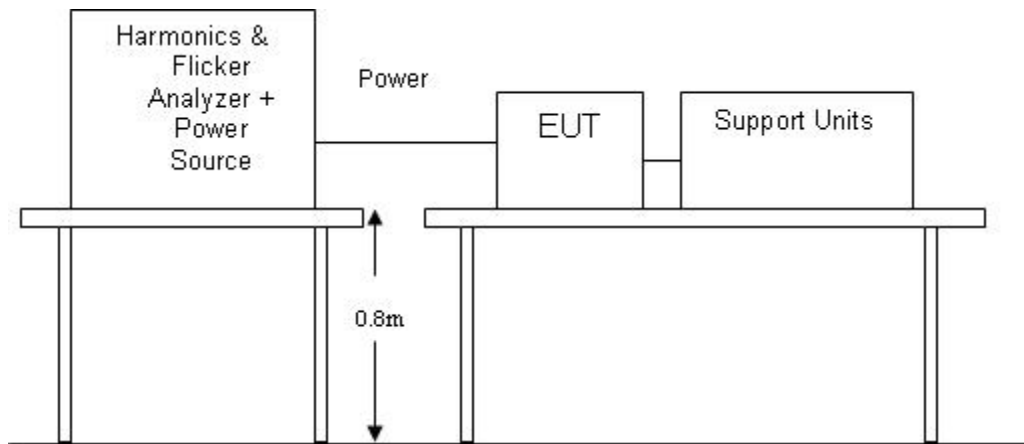

#### 4.3.3 Test Result

**Harmonic current emission:**

PASS

**Voltage fluctuations & flicker:**

PASS

## 5 Immunity test

### 5.1 Electrostatic discharge immunity (ESD)

#### 5.1.1 Test Method

##### PERFORMANCE CRITERIA DESCRIPTION

##### EN 301 489-1 V2.2.3 Clause 6 requirements:

##### Performance criteria for continuous phenomena

During the test, the equipment shall:

- continue to operate as intended;
- not unintentionally transmit;
- not unintentionally change its operating state;
- not unintentionally change critical stored data

##### Performance criteria for transient phenomena

For all ports and transient phenomena with the exception described below, the following applies:

- The application of the transient phenomena shall not result in a change of the mode of operation (e.g. unintended transmission) or the loss of critical stored data.
- After application of the transient phenomena, the equipment shall operate as intended.

For surges applied to symmetrically operated wired network ports intended to be connected directly to outdoor lines the following criteria applies:

- For products with only one symmetrical port intended for connection to outdoor lines, loss of function is allowed, provided the function is self-recoverable, or can be otherwise restored. Information stored in non-volatile memory, or protected by a battery backup, shall not be lost.
- For products with more than one symmetrical port intended for connection to outdoor lines, loss of function on the port under test is allowed, provided the function is self-recoverable. Information stored in non-volatile memory, or protected by a battery backup, shall not be lost.

##### EN 301 489-17 V3.2.4 Clause 6 requirements:

6 General performance criteria

6.1 The performance criteria are:

- performance criteria A for immunity tests with phenomena of a continuous nature;
- performance criteria B for immunity tests with phenomena of a transient nature;
- performance criteria C for immunity tests with power interruptions exceeding a certain time.

The equipment shall meet the minimum performance criteria as specified in the following clauses.

#### 5.1.2 Performance criteria

According to EN 301489-17 standard, the general performance criteria as following:

Criteria	During the test	After the test
A	Shall operate as intended. (see note 1). Shall be no loss of function. Shall be no unintentional transmissions	Shall operate as intended. Shall be no degradation of performance (see note 3). Shall be no loss of function. Shall be no loss of stored data or user programmable functions
B	May show loss of function (one or more). May show degradation of performance (see note 2). Shall be no unintentional transmissions.	Functions shall be self-recoverable. Shall operate as intended after recovering. Shall be no degradation of performance (see note 3). Shall be no loss of stored data or user programmable functions.
C	May be loss of function (one or more)	Functions shall be recoverable by the operator. Shall operate as intended after recovering. Shall be no degradation of performance (see note 3).

NOTE 1: Operate as intended during the test allows a level of degradation not below a minimum performance level specified by the manufacturer for the use of the apparatus as intended. In some cases the specified minimum performance level may be replaced by a permissible degradation of performance. If the minimum

performance level or the permissible performance degradation is not specified by the manufacturer then either of these may be derived from the product description and documentation (including leaflets and advertising) and what the user may reasonably expect from the apparatus if used as intended.

NOTE 2: Degradation of performance during the test is understood as a degradation to a level not below a minimum performance level specified by the manufacturer for the use of the apparatus as intended. In some cases the specified minimum performance level may be replaced by a permissible degradation of performance.

If the minimum performance level or the permissible performance degradation is not specified by the manufacturer then either of these may be derived from the product description and documentation (including leaflets and advertising) and what the user may reasonably expect from the apparatus if used as intended.

NOTE 3: No degradation of performance after the test is understood as no degradation below a minimum performance level specified by the manufacturer for the use of the apparatus as intended. In some cases the specified minimum performance level may be replaced by a permissible degradation of performance. After the test no change of actual operating data or user retrievable data is allowed. If the minimum performance level or the permissible performance degradation is not specified by the manufacturer then either of these may be derived from the product description and documentation (including leaflets and advertising) and what the user may reasonably expect from the apparatus if used as intended.

### **PERFORMANCE FOR TT**

The performance criteria B shall apply, except for voltage dips of 100 ms and voltage interruptions of 5 000 ms duration, for which performance criteria C shall apply. Tests shall be repeated with the EUT in standby mode (if applicable) to ensure that unintentional transmission does not occur. In systems using acknowledgement signals, it is recognized that an acknowledgement (ACK) or not-acknowledgement (NACK) transmission may occur, and steps should be taken to ensure that any transmission resulting from the application of the test is correctly interpreted.

### **PERFORMANCE FOR TR**

The performance criteria B shall apply, except for voltage dips of 100 ms and voltage interruptions of 5 000 ms duration for which performance criteria C shall apply. Where the EUT is a transceiver, under no circumstances, shall the transmitter operate unintentionally during the test. In systems using acknowledgement signals, it is recognized that an ACK or NACK transmission may occur, and steps should be taken to ensure that any transmission resulting from the application of the test is correctly interpreted.

### **PERFORMANCE FOR CT**

The performance criteria A shall apply. Tests shall be repeated with the EUT in standby mode (if applicable) to ensure that unintentional transmission does not occur. In systems using acknowledgement signals, it is recognized that an Acknowledgement (ACK) or Not Acknowledgement (NACK) transmission may occur, and steps should be taken to ensure that any transmission resulting from the application of the test is correctly interpreted.

**PERFORMANCE FOR CR**

The performance criteria A shall apply. Where the EUT is a transceiver, under no circumstances, shall the transmitter operate unintentionally during the test. In systems using acknowledgement signals, it is recognized that an ACK or NACK transmission may occur, and steps should be taken to ensure that any transmission resulting from the application of the test is correctly interpreted.

**5.1.3 Test Setup**

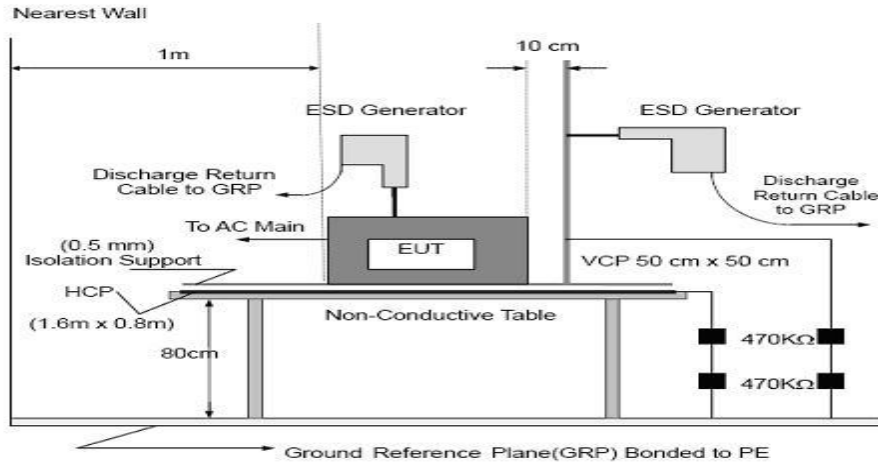

**5.1.4 Test Result**

EUT:	Static Var Generator	Model Name:	SVG-400-35K-4L
Temperature:	25°C	Relative Humidity:	61%
Pressure:	101kPa	Test mode:	All Modes

**Indirect discharge**

Test Point	Contact discharge level (kV)	Number and polarity	Criterion met	Criterion Required
1. VCP-Front side	<input type="checkbox"/> ..2 <input checked="" type="checkbox"/> ..4	10 (+)	A	B
	<input type="checkbox"/> ..6 <input type="checkbox"/> ..8	10 (-)	A	
2.VCP-Rear side	<input type="checkbox"/> ..2 <input checked="" type="checkbox"/> ..4	10 (+)	A	
	<input type="checkbox"/> ..6 <input type="checkbox"/> ..8	10 (-)	A	
3.VCP-Left side	<input type="checkbox"/> ..2 <input checked="" type="checkbox"/> ..4	10 (+)	A	
	<input type="checkbox"/> ..6 <input type="checkbox"/> ..8	10 (-)	A	
4. VCP-Right side	<input type="checkbox"/> ..2 <input checked="" type="checkbox"/> ..4	10 (+)	A	
	<input type="checkbox"/> ..6 <input type="checkbox"/> ..8	10 (-)	A	
5. HCP	<input type="checkbox"/> ..2 <input checked="" type="checkbox"/> ..4	10 (+)	A	
	<input type="checkbox"/> ..6 <input type="checkbox"/> ..8	10 (-)	A	

**Result: Compliance.**

**Direct discharge**

Test Point	discharge level(kV)	Air discharge level(kV)	Number and polarity	Criterion met	Observation	Criterion Required
1. Each nonconductive location touchable by hand	<input type="checkbox"/> ..2 <input type="checkbox"/> ..4	<input type="checkbox"/> ..2 <input type="checkbox"/> ..4	10 (+)	B	TT,TR	B
	<input type="checkbox"/> ..6 <input type="checkbox"/> ..8	<input type="checkbox"/> ..6 <input checked="" type="checkbox"/> ..8	10 (-)	B		
1. Each conductive location touchable by hand	<input type="checkbox"/> ..2 <input checked="" type="checkbox"/> ..4	<input type="checkbox"/> ..2 <input type="checkbox"/> ..4	10 (+)	B		
	<input type="checkbox"/> ..6 <input type="checkbox"/> ..8	<input type="checkbox"/> ..6 <input type="checkbox"/> ..8	10 (-)	B		

**Result: compliance.**

**5.2 RF electromagnetic field immunity (RS)**

**5.2.1 Test Method**

The test method shall be in accordance with EN 61000-4-3.

The testing was performed in a fully anechoic chamber. The transmit antenna was located at a distance of 3 meters from the EUT.

The frequency range is swept from 80 MHz to 1000 MHz, with the signal 80% amplitude modulated with a 1 kHz sine-wave. The rate of sweep did not exceed  $1.5 \times 10^{-3}$  decade/s, where the frequency range is swept incrementally, the step size was 1 % of preceding frequency value.

The dwell time at each frequency shall be not less than the time necessary for the EUT to be able to respond.

The test was performed with the EUT exposed to both vertically and horizontally polarized fields on each of the four sides.

**5.2.2 Performance criteria**

For transmitters the performance criteria for continuous phenomena for transmitters shall apply.

For receivers the performance criteria for continuous phenomena for receivers shall apply.

For ancillary equipment the pass/failure criteria supplied by the manufacturer shall apply, unless the ancillary equipment is tested in connection with a receiver or transmitter in which case the corresponding performance criteria above shall apply.

**5.2.3 Test setup**

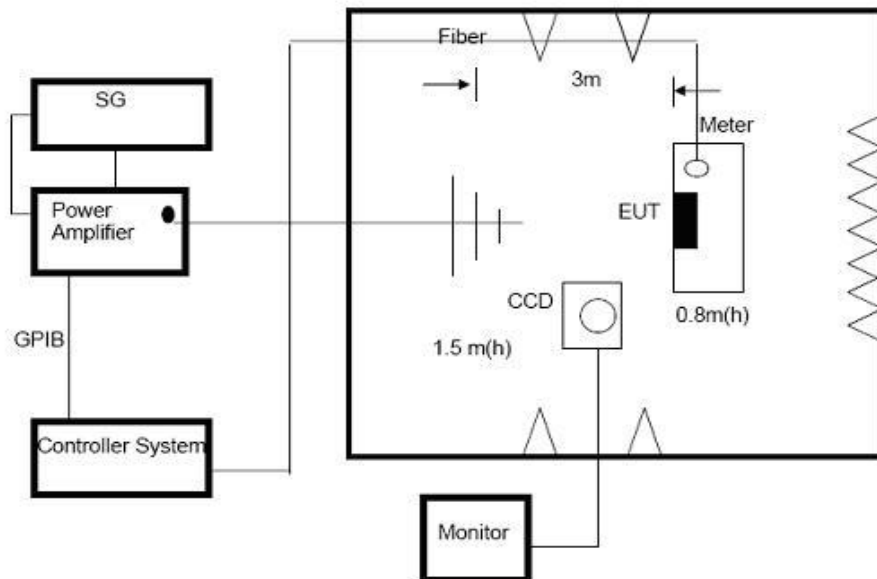

EUT:	Static Var Generator	Model Name:	SVG-400-35K-4 L
Temperature:	25°C	Relative Humidity:	60%
Pressure:	101kPa	Test mode:	All Modes

Frequency Range (MHz)	RF Field Position	R.F. Field Strength	Azimuth	Observation	Criterion met	Criterion Required
80~6000	H / V	3 V/m (rms) AM Modulated 1000Hz, 80%	Front	CT,CR	A	A
			Rear			
			Left			
			Right			

**Result: compliance.**

Note:

1. The exclusion band has not been tested in 80MHz~6GHz.

The exclusion band for immunity testing of equipment operating in the 2,4 GHz band shall be: •  
lower limit of exclusion band = lowest allocated band edge frequency -120 MHz, i.e. 2280 MHz; •  
upper limit of exclusion band = highest allocated band edge frequency +120 MHz, i.e. 2603,5MHz.

2. "A" stand for, during test, operate as intended no loss of function, no degradation of performance, no unintentional transmissions and after test, no degradation of performance, no loss of function, no loss of stored data or user programmable functions.

### 5.3 Fast transients immunity (EFT)

#### 5.3.1 Test Procedures

The test method shall be in accordance with EN 61000-4-4.

The following requirements and evaluation of test results shall apply:

- the test level for signal ports, telecommunication ports, and control ports shall be 0.5kV open circuit voltage at a repetition rate of 5kHz as given in EN 61000-4-4;
- the test level for DC power input ports shall be 0.5kV open circuit voltage as given EN 61000-4-4;
- the test level for AC mains power input ports shall be 1kV open circuit voltage as given EN 61000-4-4.

#### 5.3.2 Performance criteria

For transmitters the performance criteria for transient phenomena for transmitter shall apply.

For receivers the performance criteria for transient phenomena for receivers shall apply.

For ancillary equipment the pass/failure criteria supplied by the manufacturer shall apply, unless the ancillary equipment is tested in connection with a receiver or transmitter in which case the corresponding performance criteria shall apply.

#### 5.3.3 Test Setup

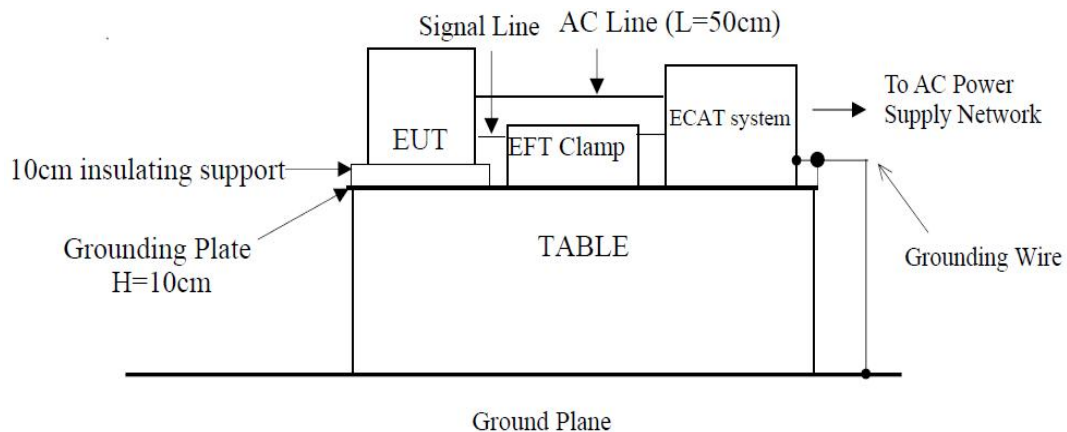

#### 5.3.4 Test Result:

Temperature:	25.2°C	Relative Humidity:	57%
Pressure:	101kPa	Test mode:	All Modes

Port Type	Injected Line	Test Voltage	Criterion met	Criterion Required	Result
AC Mains	L-N	±1kV	B	B	Compliance
	N-PE	/	/		
	L-PE	/	/		
	L+N-PE	/	/		

Note: +/- 1KV for AC mains port; +/- 0.5KV for analogue digital data ports and DC network power port.

**5.4.1 Test Method**

The test method shall be in accordance with EN 61000-4-5.

**Test method for telecommunication ports directly connected to outdoor cables:**

The test level for telecommunications ports, intended to be directly connected to the telecommunications network via outdoor cables, shall be 1kV line to ground as given in EN 61000-4-5, however, in telecommunications centres 0.5kV line to ground shall be used. In this case the total output impedance of the surge generator shall be in accordance with the basic standard EN 61000-4-5. The test generator shall provide the 1.2/50µs pulse as defined in EN 61000-4-5.

**Test method for telecommunication ports connected to indoor cables:**

The test level for telecommunication ports, intended to be connected to indoor cables (longer than 10m) shall be 0.5kV line to ground. In this case the total output impedance of the surge generator shall be in accordance with the basic standard EN 61000-4-5. The test generator shall provide the 1,2/50µs pulse as defined in EN 61000-4-5.

**Test method for mains ports:**

The test level for ac mains power input ports shall be 2kV line to ground, and 1kV line to line, with the output impedance of the surge generator as given in EN 61000-4-5. In telecom centres 1kV line to ground and 0,5kV line to line shall be used. The test generator shall provide the 1,2/50µs pulse as defined in EN 61000-4-5.

**5.4.2 Performance criteria**

For transmitters the performance criteria for transient phenomena for transmitters shall apply.

For receivers the performance criteria for transient phenomena for receivers shall apply.

For ancillary equipment the pass/failure criteria supplied by the manufacturer shall apply, unless the ancillary equipment is tested in connection with a receiver or transmitter in which case the corresponding performance criteria above shall apply.

**5.4.3 Test Setup**

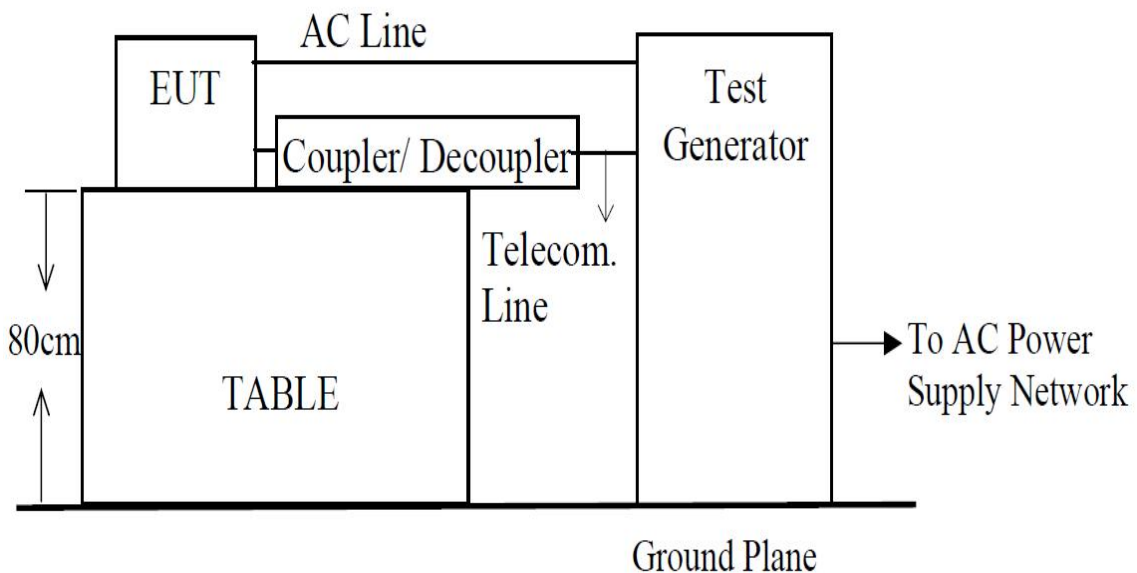

**5.4.4 Test Result**

Temperature:	24.9°C	Relative Humidity:	59%
Pressure:	101kPa	Test mode:	All Modes

Port Type	Injected Line	Test Voltage	Criterion met	Criterion Required	Result
AC Mains	L – N	±0.5kV, ±1kV	B	B	Compliance
	L – PE	/	/		
	N – PE	/	/		
	L+N – PE	/	/		

## 5.5 Injected current immunity (CS)

### 5.5.1 Test Method

The test method shall be in accordance with EN 61000-4-6.

The following requirements and evaluation of test results shall apply:

- the test level shall be severity level 2 as given in EN 61000-4-6 corresponding to 3V rms unmodulated. The test signal shall then be amplitude modulated to a depth of 80% by a sinusoidal audio signal of 1000Hz. If the wanted signal is modulated at 1000Hz, then the test signal of 400Hz shall be used;
- the test shall be performed over the frequency range 150kHz to 80MHz with the exception of an exclusion band for transmitters, and for receivers and duplex transceivers;
- for receivers and transmitters the stepped frequency increments shall be 1% frequency increment of the momentary frequency in the frequency range 150kHz to 80MHz;
- the injection method to be used shall be selected according to the basic standard EN 61000-4-6;
- responses on receivers or receiver parts of transceivers occurring at discrete frequencies which are narrow band responses (spurious responses), are disregarded from the test;

### 5.5.2 Performance criteria

For transmitters the performance criteria for continuous phenomena for transmitter shall apply.

For receivers the performance criteria for continuous phenomena for receivers shall apply.

For ancillary equipment the pass/failure criteria supplied by the manufacturer shall apply, unless the ancillary equipment is tested in connection with receivers or transmitters in which case the corresponding performance criteria above shall apply.

### 5.5.3 Test Setup

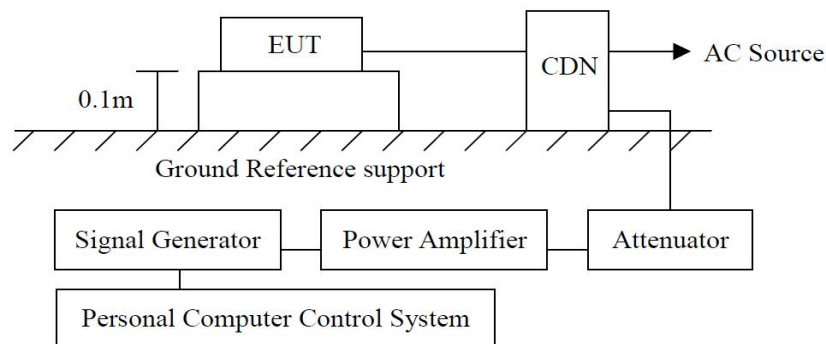

### 5.5.4 Test Result

Temperature:	24.9°C	Relative Humidity:	57%
Pressure:	101kPa	Test mode:	All Modes

Port Type	Frequency (MHz)	Test Voltage	Criterion met	Criterion Required	Result
AC Mains	0.15 to 80	3 V (rms) AM Modulated 1000Hz, 80%	A	A	Compliance

## 5.6 Voltage interruptions voltage Dips

### 5.6.1 Test Method

The test method shall be in accordance with EN 61000-4-11.

The test levels shall be:

- voltage dip: 0% residual voltage for 0.5 cycle;
- voltage dip: 0% residual voltage for 1 cycle;
- voltage dip: 70% residual voltage for 25 cycles (at 50Hz);
- voltage interruption: 0% residual voltage for 250 cycles (at 50 Hz).

### 5.6.2 Performance criteria

**For a voltage dip the following performance criteria apply:**

- for transmitters the performance criteria for transient phenomena for transmitter shall apply;
- for receivers the performance criteria for transient phenomena for receiver shall apply;
- for ancillary equipment the pass/failure criteria supplied by the manufacturer shall apply, unless the ancillary equipment is tested in connection with a receiver or transmitter in which case the corresponding performance criteria above shall apply.

**For a voltage interruption the following performance criteria apply:**

- in the case where the equipment is fitted with or connected to a battery back-up, the performance criteria for transient phenomena for transmitters or for receivers shall apply;
- in the case where the equipment is powered solely from the AC mains supply (without the use of a parallel battery back-up) volatile user data may have been lost and if applicable the communication link need not to be maintained and lost functions should be recoverable by user or operator;
- no unintentional responses shall occur at the end of the test; • in the event of loss of function(s) or in the event of loss of user stored data, this fact shall be recorded in the test report;
- for ancillary equipment the pass/failure criteria supplied by the manufacturer shall apply, unless the ancillary equipment is tested in connection with

### 5.6.3 Test Setup

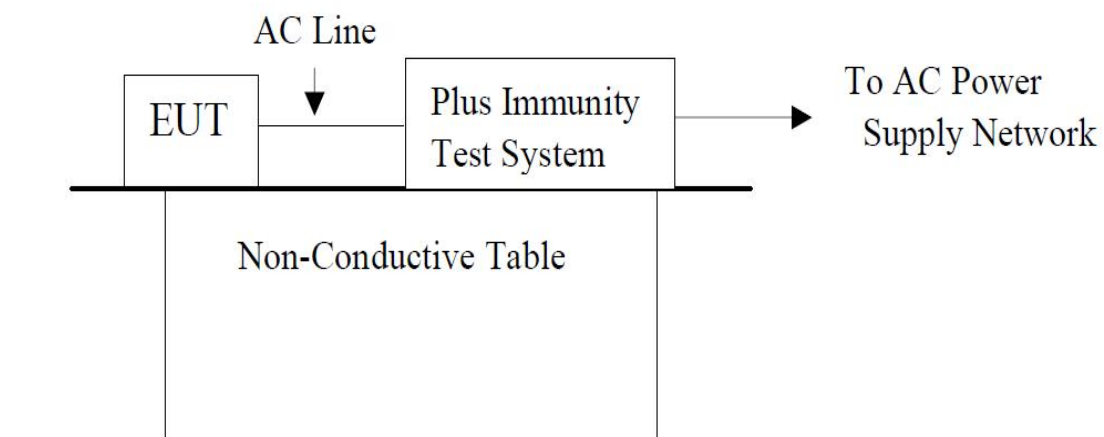

**5.6.4 Test Result**

Test Level in %UT	Period	Criterion	Result	Result
0%	0.5	B	A	Compliance
0%	1.0	B	A	Compliance
70%	25	C	C	Compliance
0%	250	C	C	Compliance

**Photographs of the Test Setup**

Conducted emission test

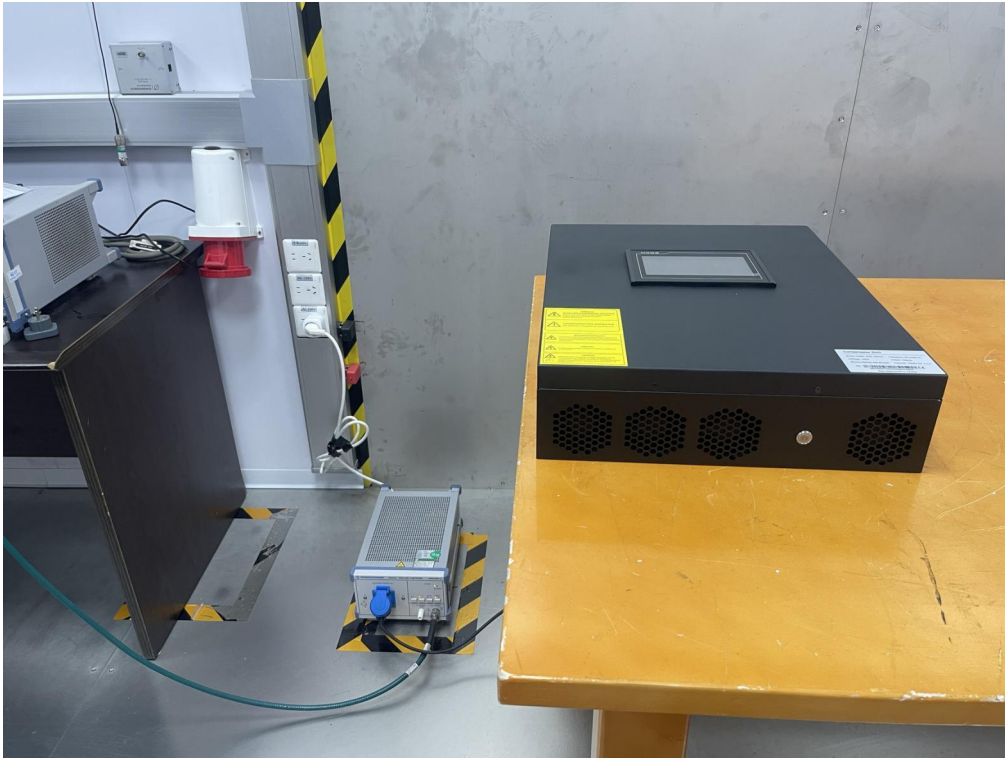

Radiated emission test(Below 1G )

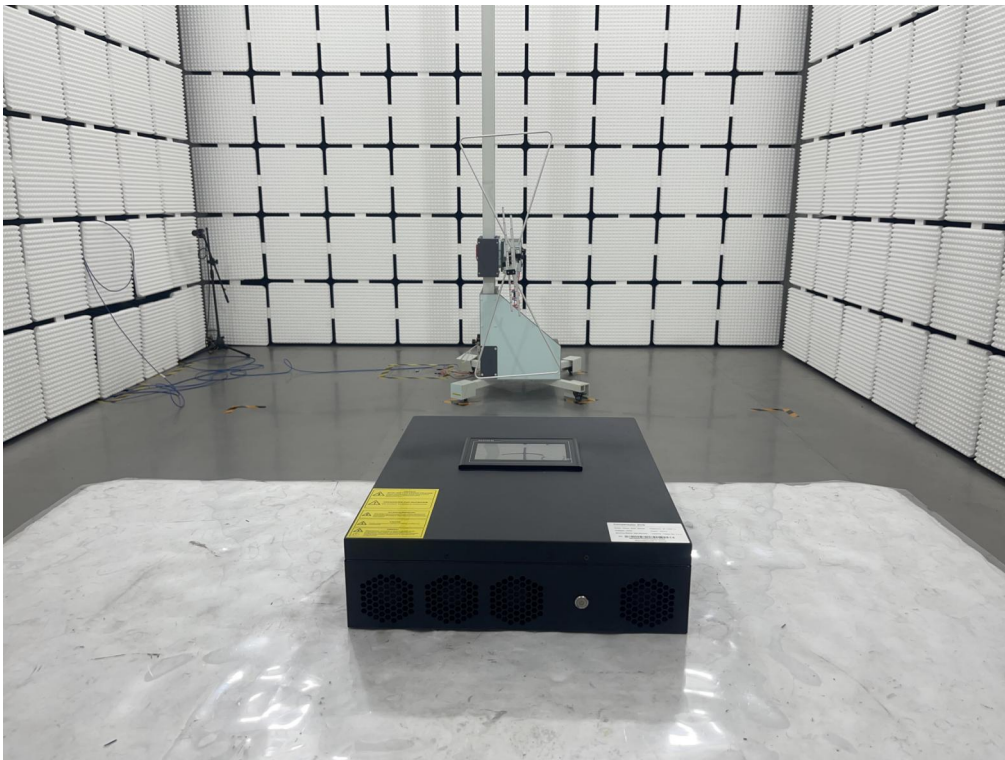

Radiated emission test(Above 1G )

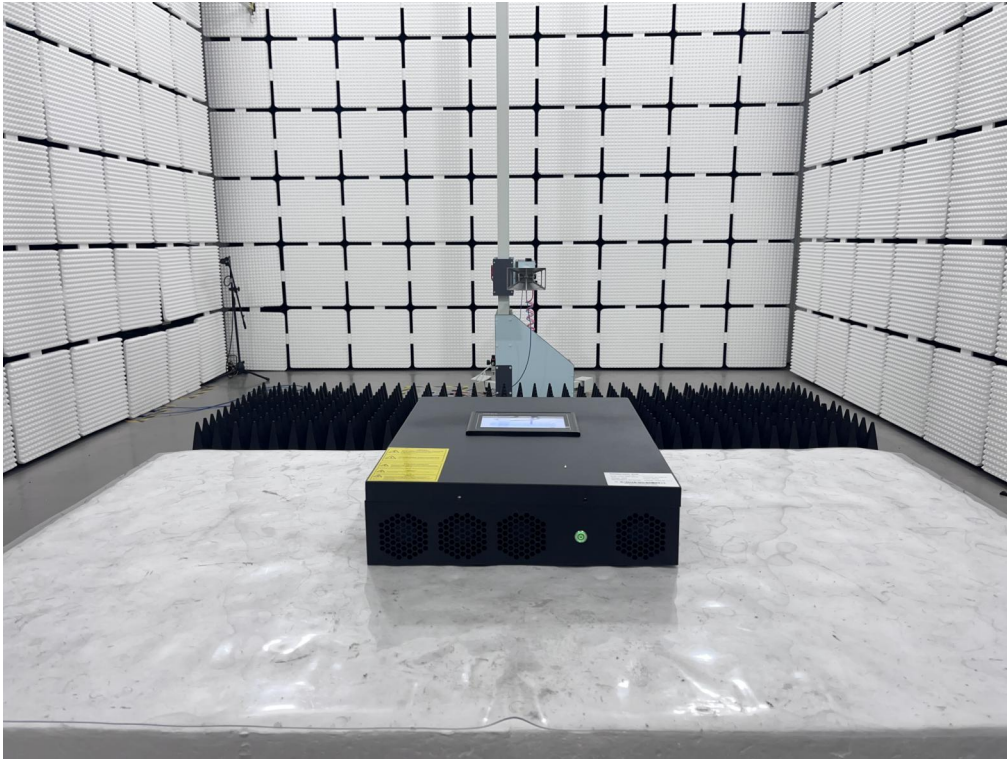

ESD test



**Photographs of the Test EUT**





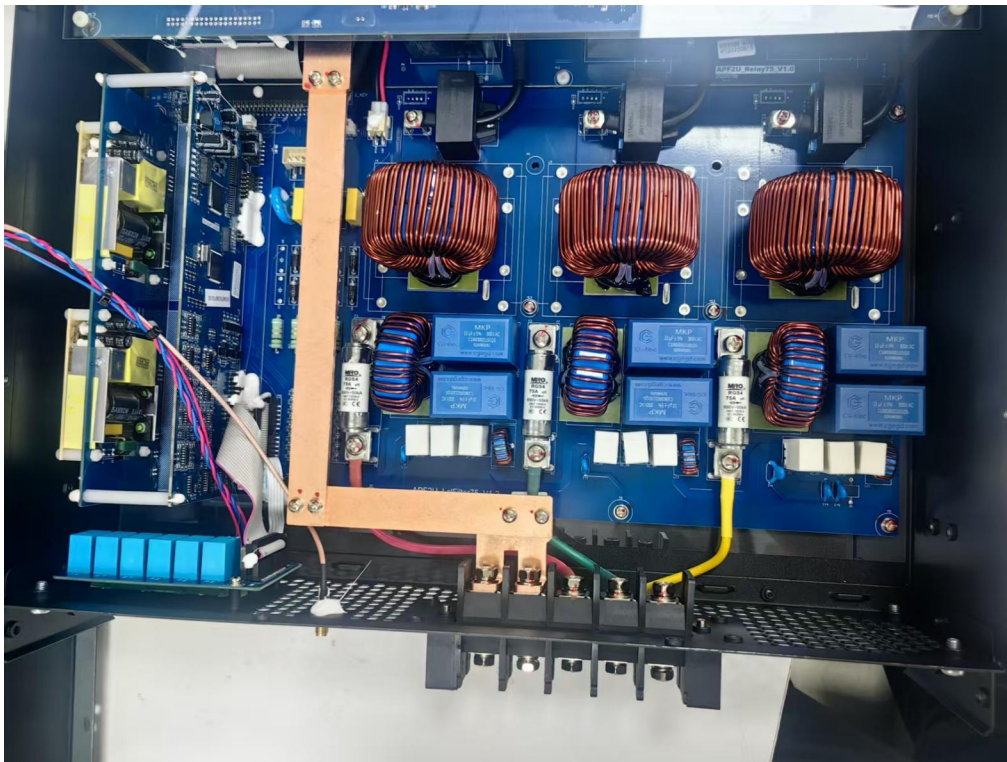
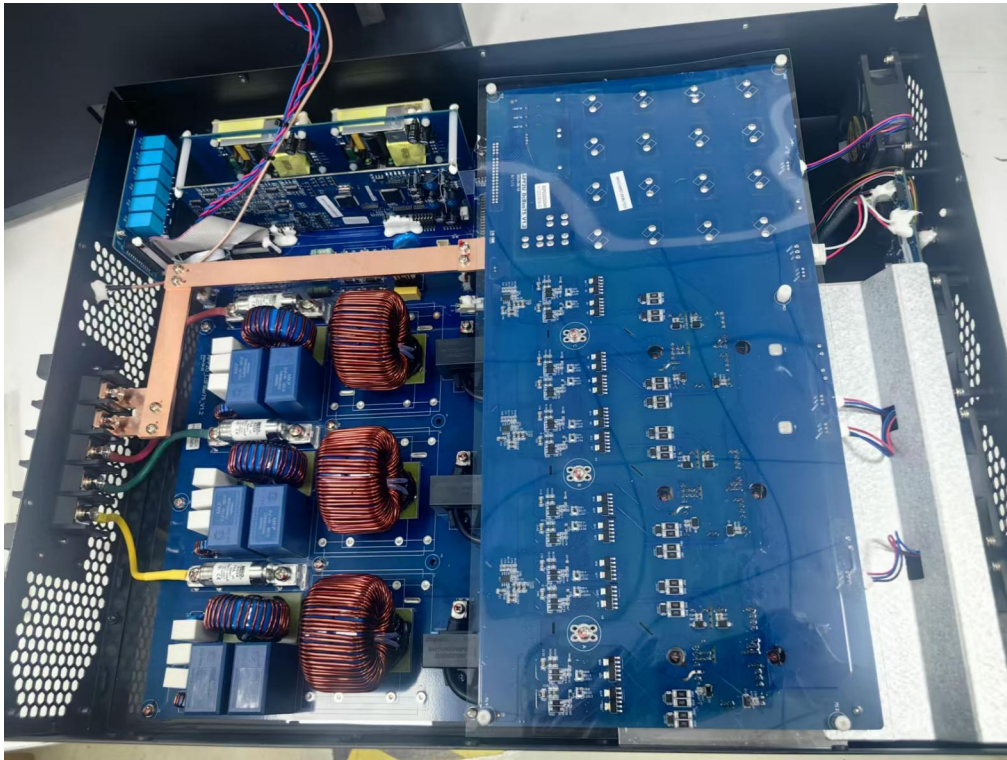



---- END OF REPORT----