

TEST REPORT

for

Capacitor

Model: RAM1.8-4320-1.2S, RAM0.75-2000-1S, RAM0.8-900-3S, RAM1.2-1000-1S,
RAM1.6-2000-0.5S, RAM3.0-11167-1S, RAM3.3-6350-0.7S, RAM3.6-6000-0.5S,
RAM4.0-8000-0.5S, RAM4.4-10000-0.6S, RAM5.0-8000-0.4S, RAM6.0-10000-0.3S,
RAM6.5-10000-0.35S, RAM7.0-10000-0.35S, DZMJ0.4-5800S, DZMJ0.7-2300S,
DZMJ0.9-5000S, DZMJ1.8-5000S, BAM7.2-32-1W, BAM7.2-40-1W

Prepared for: Cook Cooper Electric (shanghai) Co., Ltd.
Room A56, 4th Floor, Block B 505 Xinbei Road Minhang District
Shanghai

Prepared by: RED Laboratories Inc.
Room 101, Building A, Zhengtailai Hi-Tech Innovation Park, Yintian
Creative Park, Yantian Community, Xixiang Subdistrict, Bao'an District,
Shenzhen, Guangdong, China

TEL: +86-0755-23080724

Report Number: RL260414214011ED-AM
Date of Test: Apr. 07, 2026~ Apr. 14, 2026
Date of Issue: Apr. 14, 2026

Tested By: Steve Liu

Reported By: [Signature]

Reviewed By: [Signature]

The results detailed in this test report relate only to the specific sample(s) tested. It is the Application's responsibility to ensure that all production units are manufactured with equivalent EMC characteristics. This report is not to be reproduced except in full, without written approval from RED Laboratories Inc.



Table of contents

1.0 General Information	3
1.1 Client Information	3
1.2 General Description of E.U.T.	3
1.3 Test Facility:	3
2.0 List of Measurement Equipment	4
3.0 Technical Details	6
3.1 Investigations Requested	6
3.2 Test Standards	6
3.3 Performance Criteria	6
3.4 Test standards and Results Summary Tables	7
3.5 Measurement Uncertainty (95% confidence levels, k=2)	7
4.0 Electromagnetic Interference Test results	8
4.1 Power Line Conducted Emission Test	8
4.2 Telecommunication ports Conducted Emission Test	12
4.3 Radiated Emission Test	14
4.4 Harmonic Current Emissions	18
4.5 Flicker and Voltage Fluctuation	19
5.0 Immunity Test	20
5.1 Electrostatic Discharge	20
5.2 RF field strength susceptibility (80MHz----- 1000MHz)	21
5.3 Electrical Fast Transient/Burst (EFT/B) immunity test	22
5.4 Surge test	23
5.5 Conducted Immunity test	24
5.6 Power-Frequency magnetic field test	25
5.7 Voltage Dips/Interruptions immunity test	26
6.0 Photos of the EUT	27

1.0 General Information

1.1 Client Information

Application:	Cook Cooper Electric (shanghai) Co., Ltd.
Address of Application:	Room A56, 4th Floor, Block B 505 Xinbei Road Minhang District Shanghai
Manufacturer:	Cook Cooper Electric (shanghai) Co., Ltd.
Address of Manufacturer:	Room A56, 4th Floor, Block B 505 Xinbei Road Minhang District Shanghai

1.2 General Description of E.U.T.

Product Name:	Capacitor
Model:	RAM1.8-4320-1.2S
Additional Model:	RAM0.75-2000-1S, RAM0.8-900-3S, RAM1.2-1000-1S, RAM1.6-2000-0.5S, RAM3.0-11167-1S, RAM3.3-6350-0.7S, RAM3.6-6000-0.5S, RAM4.0-8000-0.5S, RAM4.4-10000-0.6S, RAM5.0-8000-0.4S, RAM6.0-10000-0.3S, RAM6.5-10000-0.35S, RAM7.0-10000-0.35S, DZMJ0.4-5800S, DZMJ0.7-2300S, DZMJ0.9-5000S, DZMJ1.8-5000S, BAM7.2-32-1W, BAM7.2-40-1W
Trade Mark:	Cooke kolb
Power Supply:	Input: 7.2KV
Memo:	According client required.
Model Difference:	All the same except the model name and appearance.
Remark:	RAM1.8-4320-1.2S is tested model, other models are derivative models, The models are identical in circuit, only different on the model name and appearance, So the test data of RAM1.8-4320-1.2S can represent the remaining models.

1.3 Test Facility:

Name of Test Lab:	RED Laboratories Inc.
Address of Test Lab:	Room 101, Building A, Zhengtailai Hi-Tech Innovation Park, Yintian Creative Park, Yantian Community, Xixiang Subdistrict, Bao'an District, Shenzhen, Guangdong, China
Telephone:	+86-0755-23080724

2.0 List of Measurement Equipment					
Conducted emission					
Name	Model No.	Serial No.	Manufacturer	Date of Cal.	Due Date
EMI Test Receiver	ESPI	101604	RS	2025/6/10	2026/6/09
LISN	ENV 216	102796	RS	2025/6/10	2026/6/09
LISN	VN1-13S	004023	CRANAGE	2025/6/10	2026/6/09
Radiated emission					
Name	Model No.	Serial No.	Manufacturer	Date of Cal.	Due Date
EMI Test Receiver	ESCI	101178	RS	2025/6/10	2026/6/09
Spectrum Analyzer	N9020A	MY50510202	Agilent	2025/6/10	2026/6/09
Amplifier	BBV 9743 B	00374	SCHWARZBECK	2025/6/10	2026/6/09
Bilog Antenna	VULB9162	00473	SCHWARZBECK	2025/3/08	2027/3/07
Horn antenna	BBHA 9120 D	02622	SCHWARZBECK	2025/3/10	2027/3/09
Preamplifier	BBV 9718D	00042	SCHWARZBECK	2025/6/10	2026/6/09
Harmonic & Flicker					
Name	Model No.	Serial No.	Manufacturer	Date of Cal.	Due Date
Harmonics Flicker Test System	AC200A	512369	LAPLACE	2025/6/10	2026/6/09
Electrostatic Discharge					
Name	Model No.	Serial No.	Manufacturer	Date of Cal.	Due Date
Electrostatic Discharge Generator	HESD 16	006315	HTEC	2025/6/12	2026/6/11
Continuous radiated disturbances					
Name	Model No.	Serial No.	Manufacturer	Date of Cal.	Due Date
Bilog Antenna	3142D	00135452	ETS	2026/04/11	2027/04/10
Amplifier (80-1000MHz)	AP801000_250	MPA1708341	SKET	2026/04/11	2027/04/10
Amplifier (1-3GHz)	AP0103_75	MPA1708342	SKET	2026/04/11	2027/04/10
Amplifier (3-6GHz)	AP0206_50	MPA1708343	SKET	2026/04/11	2027/04/10
RF Switch	/	/	EMC TOYO	2026/04/11	2027/04/10
Power Sensor	/	MY41496069	Agilent	2026/04/11	2027/04/10
Signal Generator	N5181B	MY53050432	Agilent	2026/04/11	2027/04/10

EFT/Dip					
Name	Model No.	Serial No.	Manufacturer	Date of Cal.	Due Date
Fast Transient Burst Simulator	HCOM PACT52	221003	HTEC	2025/6/16	2026/6/15
CYCLE SAG SIMULATOR	HV2P16T	221302	HTEC	2025/6/16	2026/6/15

Continuous conducted disturbances					
Name	Model No.	Serial No.	Manufacturer	Date of Cal.	Due Date
Signal Generator	CDG-7000-25	10904-1	SCHLODER	2025/6/10	2026/6/09
Power Amplifier	CDG 6050-100	191103	SCHLODER	2025/6/10	2026/6/09
CDN	M2+3	210319	SCHLODER	2025/6/10	2026/6/09

Power-frequency Magnetic field					
Name	Model No.	Serial No.	Manufacturer	Date of Cal.	Due Date
Continuous Wave Simulator	HMFG100	212305	HTEC	2025/6/10	2026/6/09

Surge					
Name	Model No.	Serial No.	Manufacturer	Date of Cal.	Due Date
Lightning Surge Generator	HOV 7000	222202	HTEC	2025/6/10	2026/6/09
Lightning Surge Generator	HIM 450	222201	HTEC	2025/6/10	2026/6/09
Lightning Surge Generator	SCDN161	222203	HTEC	2025/6/10	2026/6/09

3.0 Technical Details

3.1 Investigations Requested

Perform Electromagnetic Interference [EMI] & Electromagnetic Susceptibility [EMS] tests for CE Marking

3.2 Test Standards

EN IEC 61000-6-3:2021	Electromagnetic compatibility (EMC) - Part 6-3: Generic standards - Emission standard for residential, commercial and light-industrial environments
EN IEC 61000-6-1:2019	Electromagnetic compatibility (EMC) - Part 6-1: Generic standards - Immunity standard for residential, commercial and light-industrial environments
EN IEC 61000-3-2:2019/A2:2024	Electromagnetic compatibility(EMC)- Part 3-2:Limits-Limits for harmonic current emissions(equipment input current $\leq 16A$ per phase)
EN 61000-3-3:2013/A2:2021	Electromagnetic compatibility (EMC)- Part 3-3:Limits-Limitation of voltage changes, Voltage fluctuations and flicker in public low-voltage supply systems, for equipment with rated current $\leq 16A$ per phase and not subject to conditional connection

3.3 Performance Criteria

- Criterion A During and after the test the EUT shall continue to operate as intended without operator intervention. No degradation of performance or loss of function is allowed.
- Criterion B During the test, degradation of performance is allowed. However, no change of operating state or stored data is allowed to persist after the test.
- Criterion C During and after testing, temporary loss of function is allowed, provided the function is self-recoverable, or can be restored by the operation of the controls or cycling of the power to the EUT by the user in accordance with the manufacturer' instructions.
Functions, and/or information stored in non-volatile memory, or protected by a battery backup, shall not be lost.

3.4 Test standards and Results Summary Tables

Test Condition	Test Requirement	Test Result
EMISSION Results Summary		
Conducted Emission on AC Mains, 150KHz to 30MHz	EN IEC 61000-6-3	Pass
Conducted Emission on at telecommunication ports, 150KHz to 30MHz	EN IEC 61000-6-3	N/A
Radiated Emissions, 30MHz to 1GHz	EN IEC 61000-6-3	Pass
Harmonic Emissions on AC supply	EN IEC 61000-3-2	Pass
Voltage fluctuations on AC supply	EN 61000-3-3	Pass
IMMUNITY Results Summary		
Electrostatic Discharge	EN IEC 61000-6-1	Pass
RF field strength susceptibility	EN IEC 61000-6-1	Pass
Electrical Fast transients /Burst Immunity	EN IEC 61000-6-1	Pass
Surge	EN IEC 61000-6-1	Pass
Conducted susceptibility	EN IEC 61000-6-1	Pass
Power-frequency Magnetic Field	EN IEC 61000-6-1	N/A
Dips/Voltage Interruption Variation	EN IEC 61000-6-1	Pass

Note: N/A=Not applicable

3.5 Measurement Uncertainty (95% confidence levels, k=2)

No.	Item	MU
1.	Temperature	±0.1°C
2.	Humidity	±1.0%
3.	Spurious emissions, conducted	±3.24dB
4.	All emissions, radiated	±5.03dB

4.0 Electromagnetic Interference Test results

4.1 Power Line Conducted Emission Test

4.1.1 Schematics of the test

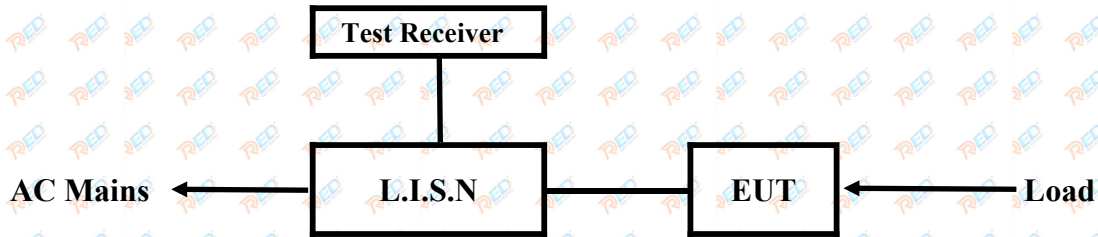

EUT: Equipment Under Test

4.1.2 Test Method and test Procedure

The test was performed in accordance with EN IEC 61000-6-3

Test Voltage: 230V~, 50Hz

Block diagram of Test setup

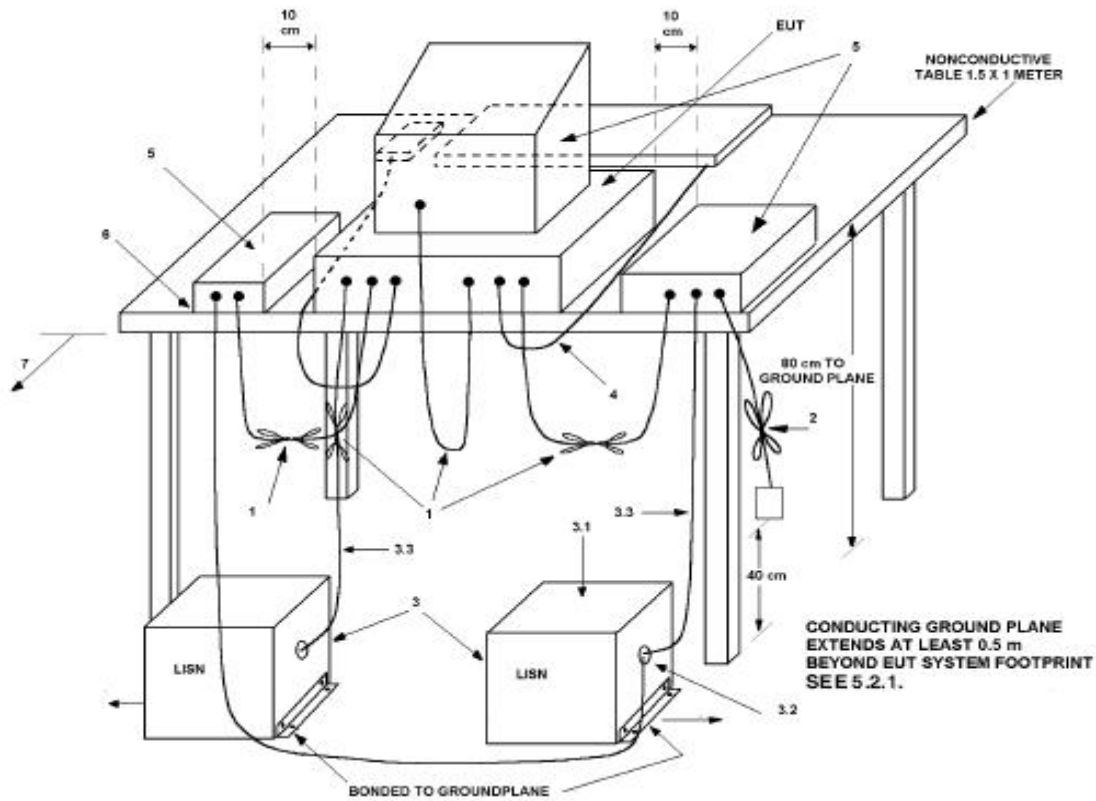

4.1.3 EUT Operating Condition

Operating condition is according to EN IEC 61000-6-3
 Setup the EUT and simulators as shown on the following

4.1.4 Test Equipment

Please refer to the Section 2

4.1.5 Power line conducted Emission Limit

Frequency(MHz)	Class A Limits (dBμV)		Class B Limits (dBμV)	
	Quasi-peak Level	Average Level	Quasi-peak Level	Average Level
0.15 ~ 0.50	79.0	66.0	66.0~56.0*	56.0~46.0*
0.50 ~ 5.00	73.0	60.0	56.0	46.0
5.00 ~ 30.00	73.0	60.0	60.0	50.0

- Notes:
- *Decreasing linearly with logarithm of frequency.
 - The tighter limit shall apply at the transition frequencies

4.1.6 Photo documentation of the test set-up

Please refer to the Section 7

4.1.7 Test specification:

Environmental conditions: Temperature: 23° C Humidity: 50% Atmospheric pressure: 103kPa

Frequency range: 0.15 MHz – 30 MHz

4.1.8 Test result

Pass

Remarks:

According to the EN IEC 61000-6-3

A Conducted Emission on Live Terminal of the power line (150kHz to 30MHz)

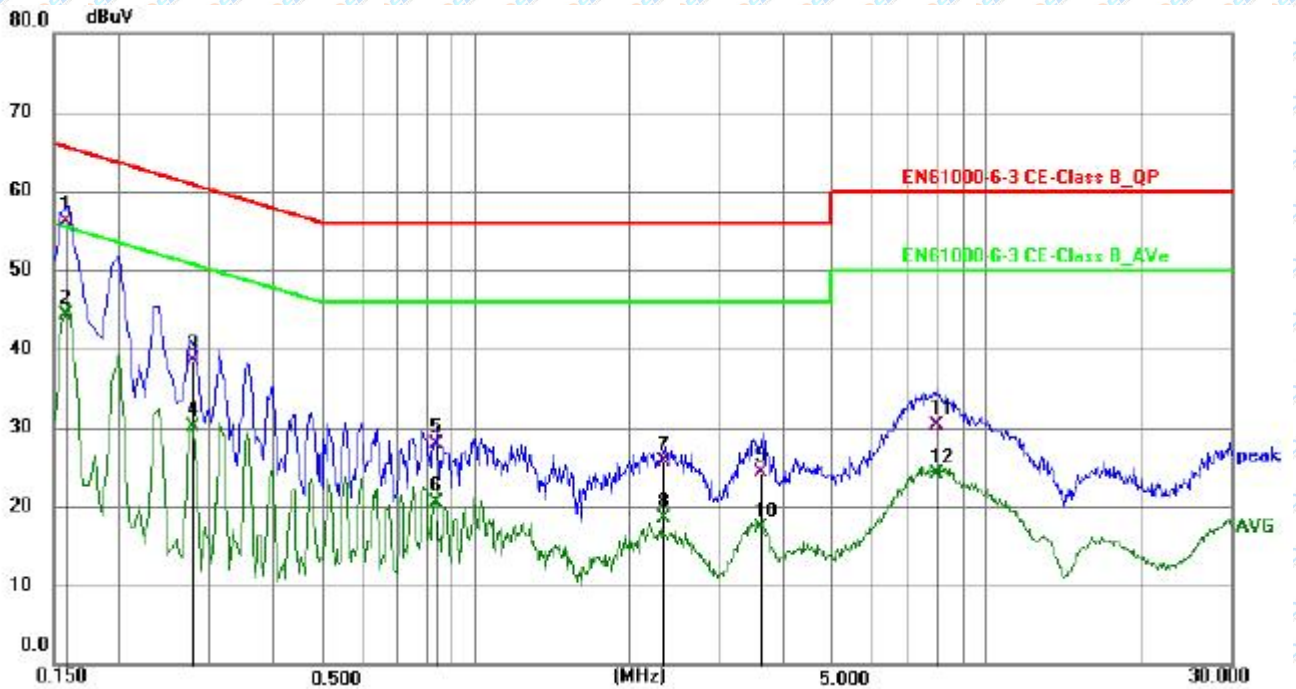

No.	Frequency (MHz)	Reading (dBuV)	Factor (dB)	Level (dBuV)	Limit (dBuV)	Margin (dB)	Detector
1 *	0.1584	36.53	19.49	56.02	65.55	-9.53	QP
2	0.1584	24.83	19.49	44.32	55.55	-11.23	AVG
3	0.2813	19.04	19.48	38.52	60.78	-22.26	QP
4	0.2813	10.54	19.48	30.02	50.78	-20.76	AVG
5	0.8446	8.42	19.50	27.92	56.00	-28.08	QP
6	0.8446	0.94	19.50	20.44	46.00	-25.56	AVG
7	2.3403	6.15	19.55	25.70	56.00	-30.30	QP
8	2.3403	-1.11	19.55	18.44	46.00	-27.56	AVG
9	3.6275	4.81	19.59	24.40	56.00	-31.60	QP
10	3.6275	-2.24	19.59	17.35	46.00	-28.65	AVG
11	7.9910	10.54	19.67	30.21	60.00	-29.79	QP
12	7.9910	4.38	19.67	24.05	50.00	-25.95	AVG

B Conducted Emission on Neutral Terminal of the power line (150kHz to 30MHz)

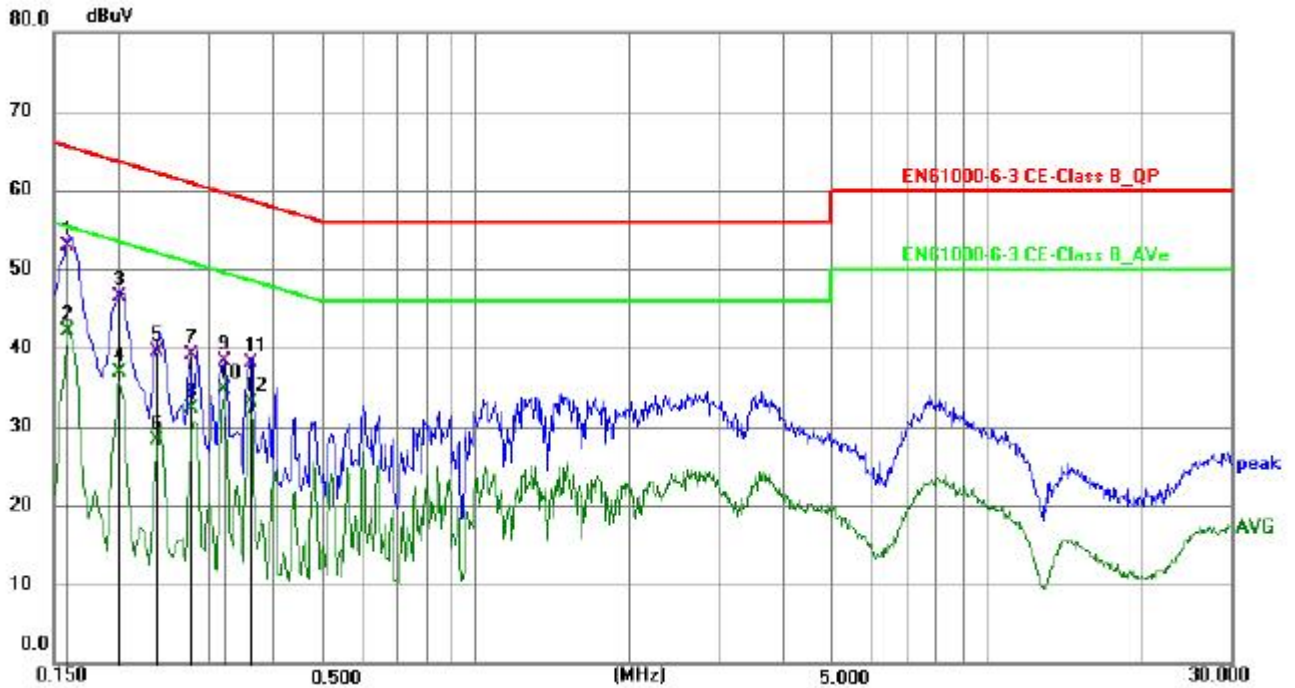

No.	Frequency (MHz)	Reading (dBuV)	Factor (dB)	Level (dBuV)	Limit (dBuV)	Margin (dB)	Detector
1 *	0.1590	33.47	19.49	52.96	65.52	-12.56	QP
2	0.1590	22.55	19.49	42.04	55.52	-13.48	AVG
3	0.2000	27.04	19.49	46.53	63.61	-17.08	QP
4	0.2000	17.34	19.49	36.83	53.61	-16.78	AVG
5	0.2390	19.98	19.48	39.46	62.13	-22.67	QP
6	0.2390	8.90	19.48	28.38	52.13	-23.75	AVG
7	0.2788	19.55	19.48	39.03	60.85	-21.82	QP
8	0.2788	12.76	19.48	32.24	50.85	-18.61	AVG
9	0.3238	18.85	19.48	38.33	59.61	-21.28	QP
10	0.3238	15.31	19.48	34.79	49.61	-14.82	AVG
11	0.3641	18.55	19.48	38.03	58.63	-20.60	QP
12	0.3641	13.63	19.48	33.11	48.63	-15.52	AVG

4.2 Telecommunication ports Conducted Emission Test

4.2.1 Test Method: The test was performed in accordance with EN IEC 61000-6-3

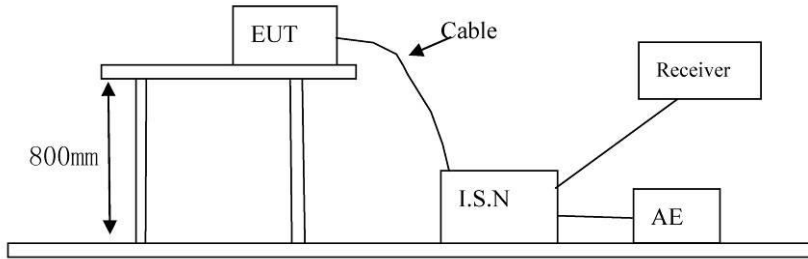

4.2.2 EUT Operating Condition

Operating condition is according to EN 61000-6-3

4.2.3 Test Equipment

Please refer to the Section 2

4.2.4 Power line conducted Emission Limit

Frequency(MHz)	Class A Limits (dBμV)		Class B Limits (dBμV)	
	Quasi-peak Level	Average Level	Quasi-peak Level	Average Level
0.15 ~ 0.50	97 to 87	84 to 74	84 to 74	74 to 64
0.50 ~ 30.00	87	74	74	64

- Notes:
- *Decreasing linearly with logarithm of frequency.
 - The tighter limit shall apply at the transition frequencies.

4.2.5 Test specification:

Environmental conditions: Temperature: 23° C Humidity: 50% Atmospheric pressure: 103kPa

Frequency range: 0.15 MHz – 30 MHz

4.2.6 Test result N/A

Remarks: According to the EN IEC 61000-6-3

A Conducted Emission on Telecommunication port (150kHz to 30MHz)

EUT Description: --
 Operation Mode: --
 Tested By: --
 Test date: --
 Test Result: --

Start Frequency Stop Frequency Step IF BW Detector Final M-Time
 0.15MHz 30MHz 4.5KHz 10KHz QP+AV 1s

Frequency (MHz)	Port	Reading(dBμA)		Limit(dBμA)	
		Quasi-peak	Average	Quasi-peak	Average

Remark: The test item is not applicable.

4.3 Radiated Emission Test

4.3.1 Schematics of the test

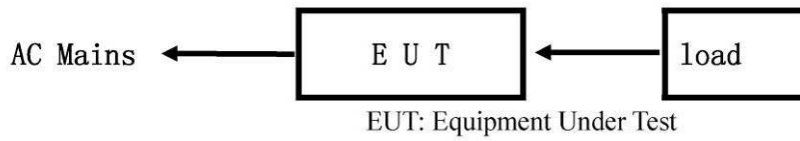

4.3.2 Test Method: The test was performed in accordance with EN IEC 61000-6-3

Block diagram of Test setup

Distance = 3m

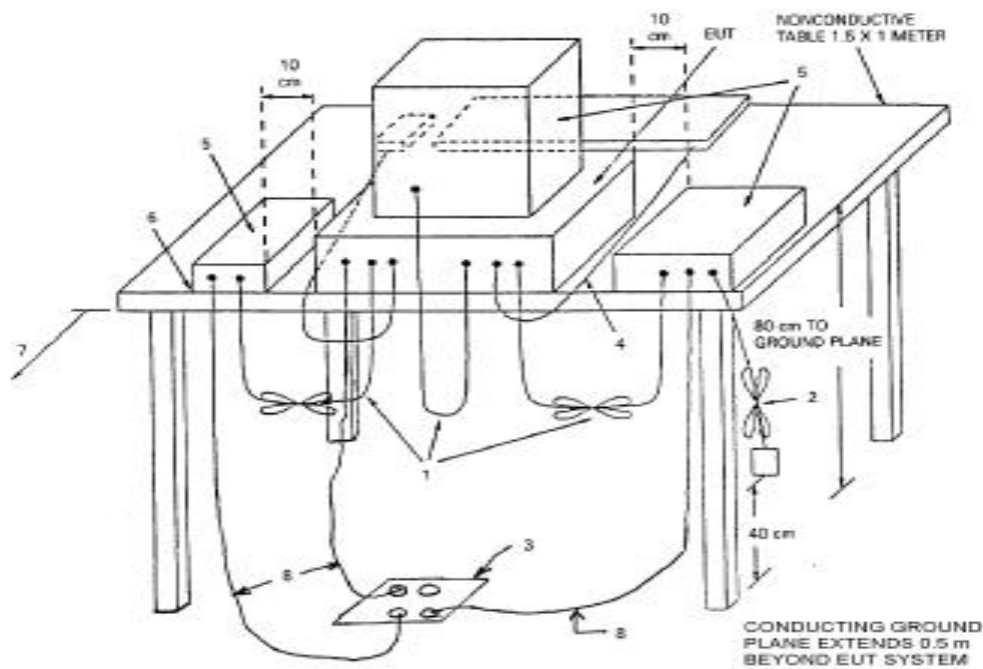
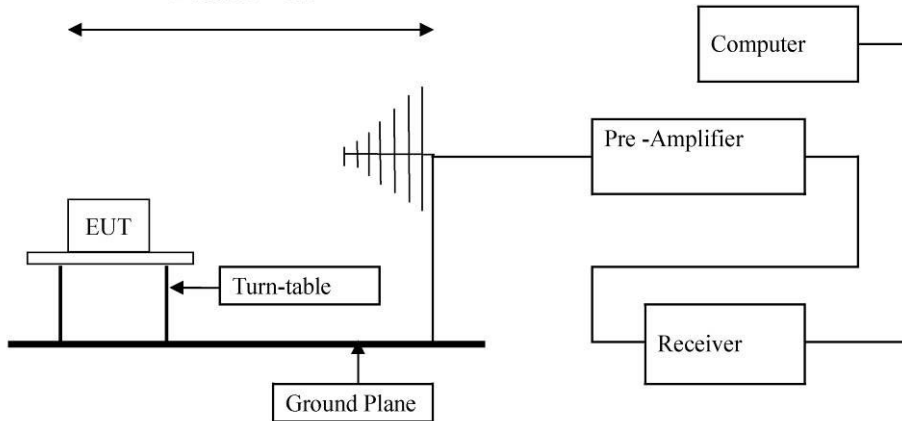

4.3.3 EUT Operating Condition

Operating condition is according to EN IEC 61000-6-3

4.3.4 Radiated Emission Limit

All emission from a digital device, including any network of conductors and apparatus connected thereto, shall not exceed the level of field strength specified below:

Frequency Range (MHz)	Distance (m)	Quasi-Peak limits (dB μ V/m)	
		Class A Limits	Class B Limits
30-230	3	50.00	40.00
230-1000	3	57.00	47.00

Note: 1) The lower limit shall apply at the transition frequencies
 2) If measurement is not made at 3m distance, then F.S Limitation at 3m distance is adjusted by using the formula $Ld1 = Ld2 * (d2/d1)$

4.3.5 Photo documentation of the test set-up

Please refer to the Section 7

4.3.6 Test Equipment:

Please refer to the Section 2

4.3.7 Test specification:

Environmental conditions: Temperature 26° C Humidity: 56% Atmospheric pressure: 103kPa

4.3.8 Test result Pass

Remarks: According to the EN IEC 61000-6-3

A. Radiated Emission In Horizontal (30MHz---1000MHz)



No.	Frequency (MHz)	Reading (dBuV)	Factor (dB/m)	Level (dBuV/m)	Limit (dBuV/m)	Margin (dB)	Detector
1	47.1597	47.52	-14.28	33.24	40.00	-6.76	QP
2	93.4402	51.52	-17.45	34.07	40.00	-5.93	QP
3	146.8875	53.14	-19.35	33.79	40.00	-6.21	QP
4	164.3301	52.03	-18.64	33.39	40.00	-6.61	QP
5	186.4407	51.22	-17.07	34.15	40.00	-5.85	QP
6	360.4476	52.75	-12.37	40.38	47.00	-6.62	QP

B. Radiated Emission In Vertical (30MHz---1000MHz)



No.	Frequency (MHz)	Reading (dBuV)	Factor (dB/m)	Level (dBuV/m)	Limit (dBuV/m)	Margin (dB)	Detector
1	30.5304	45.10	-16.40	28.70	40.00	-11.30	QP
2	47.3253	47.26	-14.28	32.98	40.00	-7.02	QP
3	289.0020	49.97	-13.68	36.29	47.00	-10.71	QP
4	366.8231	48.60	-12.20	36.40	47.00	-10.60	QP
5	475.4990	46.88	-10.03	36.85	47.00	-10.15	QP
6	539.4773	45.47	-9.04	36.43	47.00	-10.57	QP

4.4 Harmonic Current Emissions

4.4.1 EUT Operating Mode

Full load

4.4.2 Block Diagram of Test Setup.

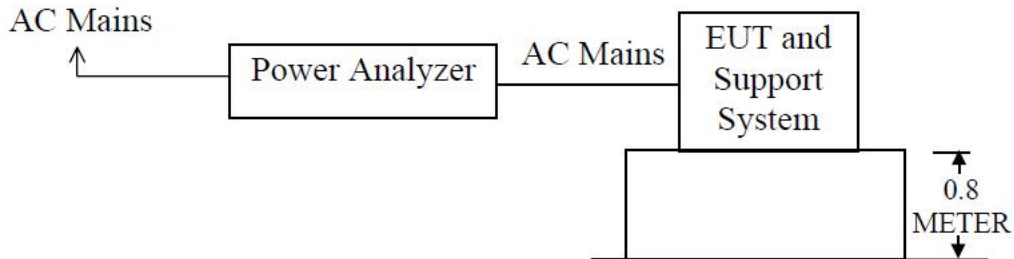

This test was performed as per EMC Basic Standard EN IEC 61000-3-2 Class A

4.4.3 Test Equipment

Please refer to Section 2 this report.

4.4.4 Test specification:

Environmental conditions: Temperature: 23° C Humidity: 54% Atmospheric pressure: 103kPa

4.4.5 Results

Port	EUT Operating mode	Result (Passed / Failed)
AC Input	Full load	Passed

Remark: --

4.5 Flicker and Voltage Fluctuation

4.5.1 EUT Operating Mode

Full load

4.5.2 Block Diagram of Test Setup.

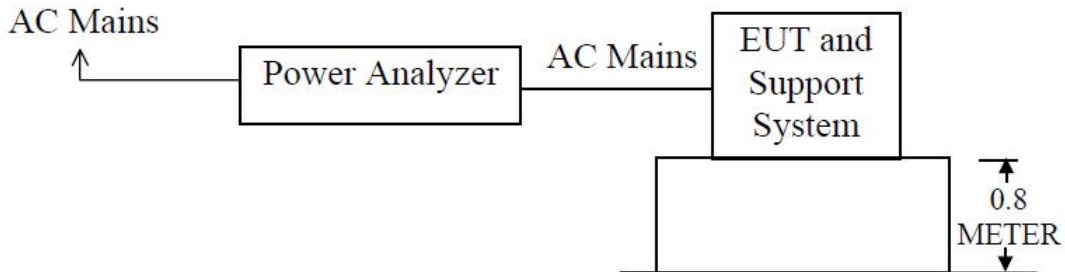

This test was performed as per EMC Basic Standard EN 61000-3-3

4.5.3 Limits of Voltage Fluctuation and Flicks Measurement

Test Item	Limit	Note
P_{st}	1.0	Pst means short-term flicker indicator
P_{lt}	0.65	Plt means long-term flicker indicator
T_{dt} (ms)	200	Tdt means maximum time that dt exceeds 3%.
d_{max} (%)	4	Dmax means maximum relative voltage change.
dc (%)	3.3	Dc means relative steady-state voltage change.

4.5.4 Test Equipment

Please refer to Section 2 this report.

4.5.5 Test specification:

Environmental conditions: Temperature: 23° C Humidity: 54% Atmospheric pressure: 103kPa

4.5.6 Results

Port	EUT Operating mode	Result (Passed / Failed)
AC Input	Full load	Passed

Remark: --

5.0 Immunity Test

5.1 Electrostatic Discharge

5.1.1 Schematic of the test

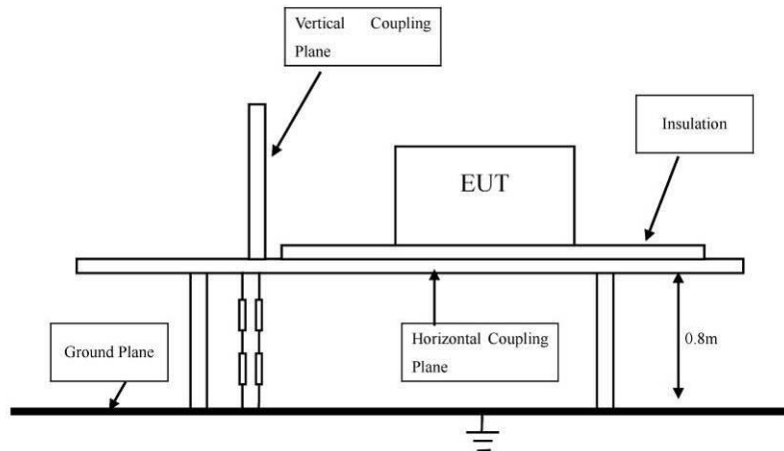

5.1.2 Test method

The test was performed in accordance with EN IEC 61000-6-1

5.1.3 Test severity

±4kV for direct & in-direct Contact Discharge

±8kV for air Discharge

Performance Criterion Require: **B**

5.1.4 Test Equipment

Please refer to Section 2 this report.

5.1.5 Test specification:

Environmental conditions: Temperature: 23° C Humidity: 54% Atmospheric pressure: 103kPa

5.1.6 Operation mode:

Charging

5.1.7 Discharge location

- HCP
- VCP
- Shell
- OUT Port

5.1.8 Test Result

Pass

5.2 RF field strength susceptibility (80MHz----- 1000MHz)

5.2.1 Test Method:

The test was performed in accordance with EN IEC 61000-6-1

Severity: Level 2 (3V/m)

Modulation: 1 KHz 80% AM

Performance Criterion Require: A

Block diagram of Test setup

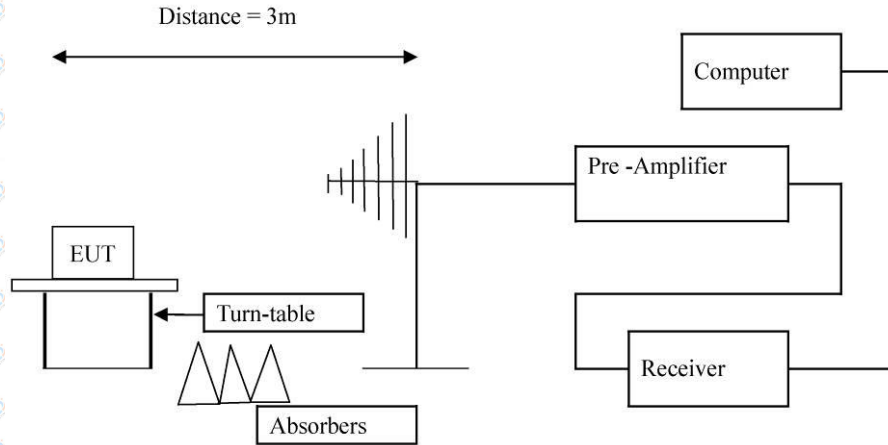

5.2.2 Test Equipment

Please refer to Section 2 this report.

5.2.3 Test specification:

Environmental conditions: Temperature: 25° C Humidity: 54% Atmospheric pressure: 103kPa

5.2.4 Operation mode: Full load

5.2.5 Test Result:

Please refer to the following table for individual results.

Frequency (MHz)	Radiation to	Polarity	Level (V/m)	Dwell Time(s)	Sweep Rate (%)	Results
80-1000	Front	H/V	3	1	1	Pass
80-1000	Rear	H/V	3	1	1	Pass
80-1000	Left	H/V	3	1	1	Pass
80-1000	Right	H/V	3	1	1	Pass
1400-6000	Front	H/V	3	1	1	Pass
1400-6000	Rear	H/V	3	1	1	Pass
1400-6000	Left	H/V	3	1	1	Pass
1400-6000	Right	H/V	3	1	1	Pass

5.3 Electrical Fast Transient/Burst (EFT/B) immunity test

5.3.1 Schematics of the test

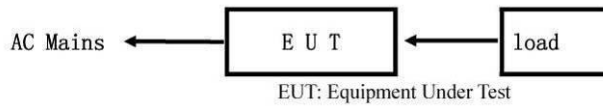

5.3.2 Test Method

The test was performed in accordance with EN IEC 61000-6-1

Severity: Level 2 (1kV)

Performance Criterion Require: **B**

Block diagram of Test setup

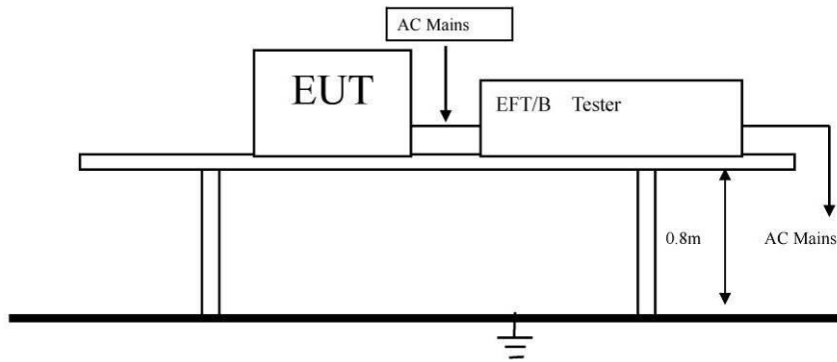

5.3.3 Test Equipment

Please refer to Section 2 this report.

5.3.4 Test specification:

Environmental conditions: Temperature: 23° C Humidity: 54% Atmospheric pressure: 103kPa

5.3.5 Operation mode: Charging

5.3.6 Test Results

Inject location: AC mains

Inject Line	Voltage kV	Inject Times (s)	Method	Results
L	±1	120	Direct	Pass
N	±1	120	Direct	Pass
L、N	±1	120	Direct	Pass
E	±1	120	Direct	N/A
L、E	±1	120	Direct	N/A
N、E	±1	120	Direct	N/A
L、N、E	±1	120	Direct	N/A

Remark: --

5.4 Surge test

5.4.1 Schematics of the test



5.4.2 Test Method:

The test was performed in accordance with EN IEC 61000-6-1

Severity: Level 2

Performance Criterion Require: B

Block diagram of Test setup

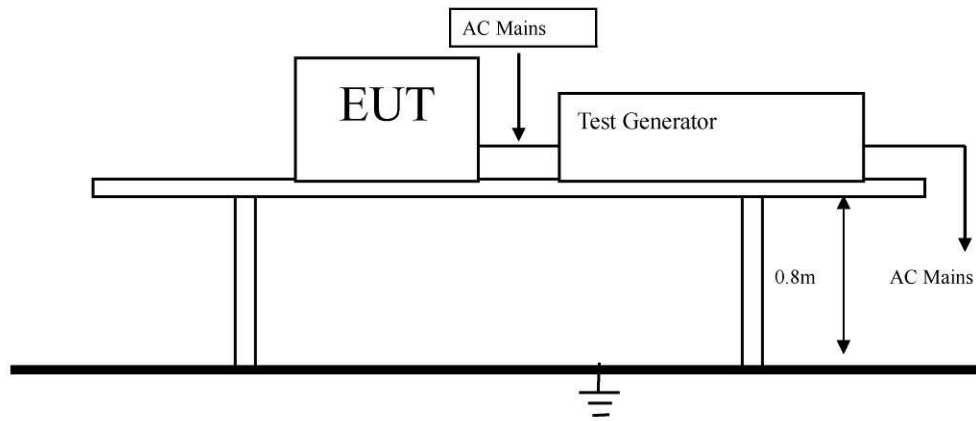

5.4.3 Test Equipment

Please refer to Section 2 this report.

5.4.4 Test specification:

Environmental conditions: Temperature: 22° C Humidity: 54% Atmospheric pressure: 103kPa

5.4.5 Operation mode: Charging

5.4.6 Test Results

5 pulses for each polarity and test voltage, and repetition rate is 1 per min.

Location	Polarity	0°	90°	180°	270°	Results
L-N	± 1 KV	Pass	Pass	Pass	Pass	Pass
L-PE	± 2 KV	N/A	N/A	N/A	N/A	N/A
N-PE	± 2 KV	N/A	N/A	N/A	N/A	N/A

Remark: --

5.5 Conducted Immunity test

5.5.1 Schematics of the test

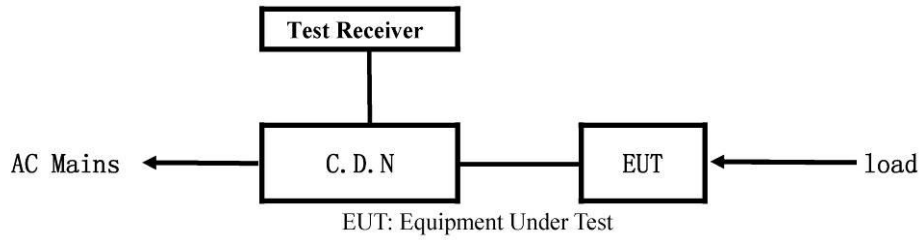

5.5.2 Test Method

The test was performed in accordance with EN IEC 61000-6-1

Severity: Level 2 (3 V rms), 0.15MHz—80MHz

Performance Criterion Require: A

Block diagram of Test setup

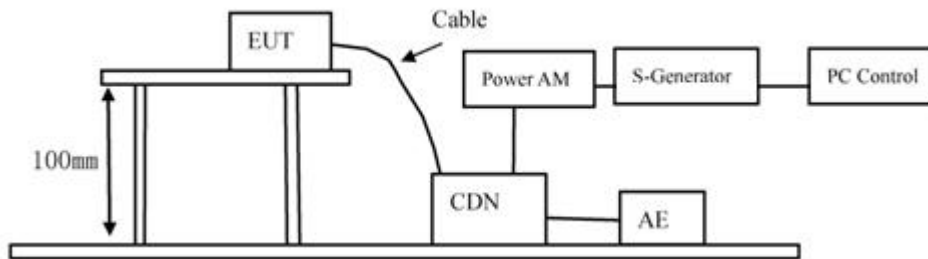

5.5.3 Test Equipment

Please refer to Section 2 this report.

5.5.4 Test specification:

Environmental conditions: Temperature: 23° C Humidity: 54% Atmospheric pressure: 103kPa

5.5.5 Operation mode:

Charging

5.5.6 Test Results:

Frequency Range (MHz)	Injected Position	Strength	Criterion	Result
0.15 - 80	AC Line	3V (rms) Unmodulated	A	Pass

Remark: --

5.6 Power-Frequency magnetic field test

5.6.1 Schematics of the test

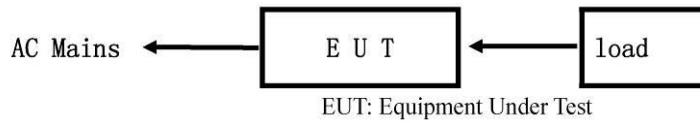

5.6.2 Test Method

The test was performed in accordance with EN IEC 61000-6-1

Severity: Level 1 (1A/m),

Performance Criterion Require: A

Block diagram of Test setup

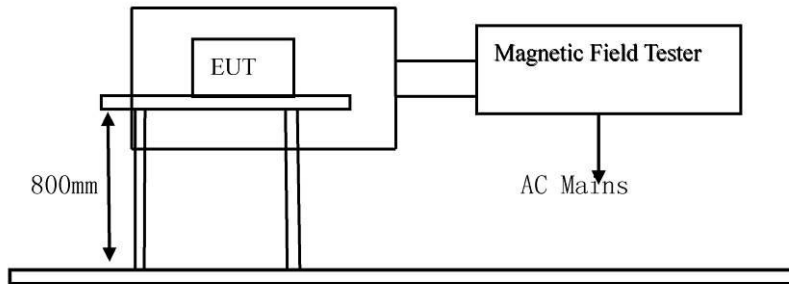

5.6.3 Test Equipment

Please refer to Section 2 this report.

5.6.4 Test specification:

Environmental conditions: Temperature: 22° C Humidity: 54% Atmospheric pressure: 103kPa

5.6.5 Operation mode: --

5.6.6 Test Results:

Test Level	Testing Duration	Coil Orientation	Criterion	Result
1A/m	5 Mins	X	A	N/A
1A/m	5 Mins	Y	A	N/A
1A/m	5 Mins	Z	A	N/A

Remark: The test item is not applicable.

5.7 Voltage Dips/Interruptions immunity test

5.7.1 Schematics of the test

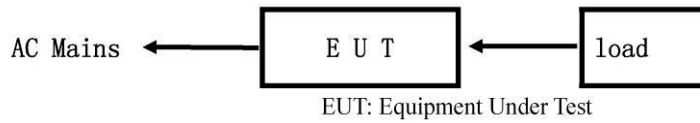

5.7.2 Test Method:

The test was performed in accordance with EN IEC 61000-6-1

Performance Criterion Require: C&B

Block diagram of Test setup

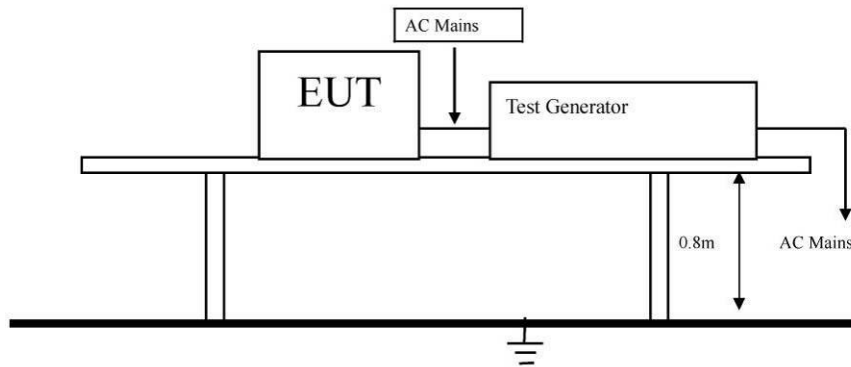

5.7.3 Test Equipment

Please refer to Section 2 this report.

5.7.4 Test specification:

Environmental conditions: Temperature: 22° C Humidity: 54% Atmospheric pressure: 103kPa

5.7.5 Operation mode: Charging

5.7.6 Test Result:

Voltage Dip: Voltage Interceptions:

Test Level % Ut	Reduction	Duration (periods)	Phase Angle	Meet Criterion	Result
0	100	0.5	0° - 360°	B	Pass
0	100	1	0° - 360°	C	Pass
70	30	25	0° - 360°	C	Pass
0	100	250	0° - 360°	C	Pass

Remark: --

6.0 Photos of the EUT

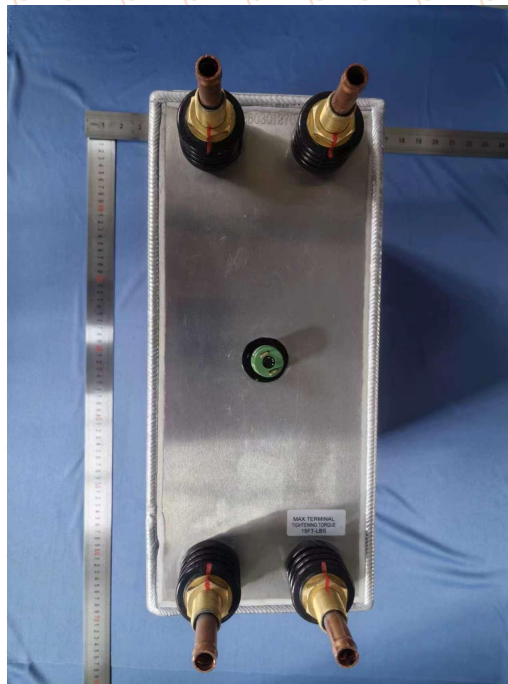

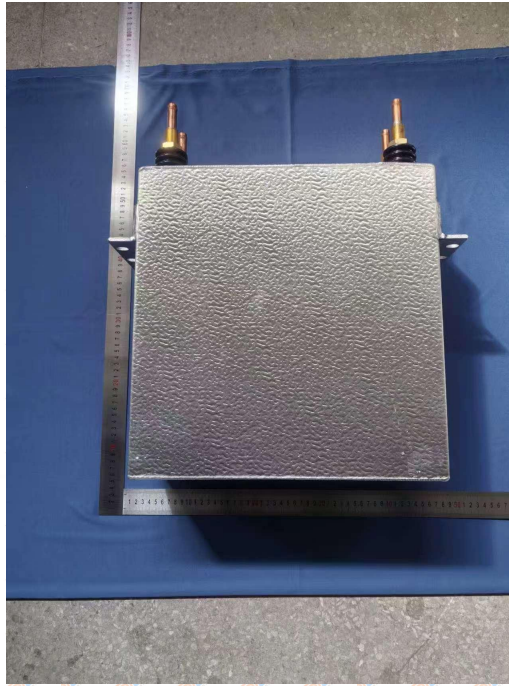

--End of the report--